



DM-55

ORDERCODE D1357



Highlite International B.V.

Vestastraat 2
6468 EX Kerkrade
The Netherlands

SHOWELECTRONICS FOR PROFESSIONALS

Congratulations!

You have bought a great, innovative product from DAP Audio.

The DAP Audio DM-55 brings excitement to any venue. Whether you want simple plug-&-play action or a sophisticated show, this product provides the effect you need.

You can rely on DAP Audio, for more excellent audio products.

We design and manufacture professional audio equipment for the entertainment industry.

New products are being launched regularly. We work hard to keep you, our customer, satisfied.

For more information: iwant@dap-audio.info

You can get some of the best quality, best priced products on the market from DAP Audio.

So next time, turn to DAP Audio for more great audio equipment.

Always get the best -- with DAP Audio !

Thank you!



DAP Audio

DAP Audio DM-55™ Product Guide

Warning	3
Safety Instructions	3
Operating Determinations.....	4
Return Procedure	4
Claims	4
Description of the device	5
Features	5
Overview	5
The microphone	6
Set Up and Operation	6
Frequency and Polar Diagrams	6
Setup example 1: Simple setup	6
Setup example 2: Advanced setup.	7
Connection Cables	7
Maintenance	8
Product Specifications	9

Warning

**FOR YOUR OWN SAFETY, PLEASE READ THIS USER MANUAL CAREFULLY
BEFORE YOUR INITIAL START-UP!**

Unpacking Instructions

Immediately upon receiving this product, carefully unpack the carton and check the contents to ensure that all parts are present, and have been received in good condition. Notify the dealer immediately and retain packing material for inspection if any parts appear damaged from shipping or the carton itself shows signs of mishandling. Save the carton and all packing materials. In the event that a fixture must be returned to the factory, it is important that the fixture be returned in the original factory box and packing.

Your shipment includes:

- DAP DM-55
- Microphone holder
- Threaded 3/8" - 5/8" adapter
- Protection bag
- User Manual



CAUTION!

Keep this system away from rain and moisture!



Safety Instructions

Every person involved with the installation, operation and maintenance of this system has to:

- be qualified
- follow the instructions of this manual



**CAUTION! Be careful with your operations.
With a dangerous voltage you can suffer
a dangerous electric shock when touching the wires!**



Before you initial start-up, please make sure that there is no damage caused by transportation. Should there be any, consult your dealer and do not use the system.

To maintain perfect condition and to ensure a safe operation, it is absolutely necessary for the user to follow the safety instructions and warning notes written in this manual.

Please consider that damages caused by manual modifications to the system are not subject to warranty.

This system contains no user-serviceable parts. Refer servicing to qualified technicians only.

IMPORTANT:

The manufacturer will not accept liability for any resulting damages caused by the non-observance of this manual or any unauthorized modification to the system.

- Always check carefully before connecting your microphone, that the phantom power is switched off, as this might damage the microphone.
- Never remove warning or informative labels from the unit.
- Do not open the device and do not modify the device.
- Only use system indoor, avoid contact with water or other liquids.
- Avoid flames and do not put close to flammable liquids or gases.
- Make sure you don't use the wrong kind of cables or defective cables.
- Make sure that the signals to the mixer are balanced, otherwise hum could be created.
- Don't put your equipment next to TV, radio, etc., because of interference or distortion.

- Please read this manual carefully and keep it for future reference. Remember that the device has a better value on the market, if you save the carton and all packing materials.
- If your Dap Audio device fails to work properly, discontinue use immediately. Pack the unit securely (preferably in the original packing material), and return it to your Dap Audio dealer for service.
- If the device has been exposed to drastic temperature fluctuation (e.g. after transportation), do not switch it on immediately. The arising condensation water might damage your system. Leave the system switched off until it has reached room temperature.
- Repairs, servicing and electric connection must be carried out by a qualified technician.

Operating Determinations

This system is not designed for permanent operation. Consistent operation breaks will ensure that the system will serve you for a long time without defects.

If this system is operated in any other way, than the one described in this manual, the product may suffer damages and the warranty becomes void.

Any other operation may lead to dangers like short-circuit, burns, electric shock, etc.

You endanger your own safety and the safety of others!

Improper installation can cause serious damage to people and property !

Return Procedure

Returned merchandise must be sent prepaid and in the original packing, call tags will not be issued. Package must be clearly labeled with a Return Authorization Number (RMA number). Products returned without an RMA number will be refused. Highlite will not accept the returned goods or any responsibility. Call Highlite 0031-455667723 or mail aftersales@highlite.nl and request an RMA prior to shipping the device. Be prepared to provide the model number, serial number and a brief description of the cause for the return. Be sure to properly pack the device, any shipping damage resulting from inadequate packaging is the customer's responsibility. Highlite reserves the right to use its own discretion to repair or replace product(s). As a suggestion, proper UPS packing or double-boxing is always a safe method to use.

Note: If you are given an RMA number, please include the following information on a piece of paper inside the box:

- 1) Your name
- 2) Your address
- 3) Your phone number
- 4) A brief description of the symptoms

Claims

The client has the obligation to check the delivered goods immediately upon delivery for any shortcomings and/or visible defects, or perform this check after our announcement that the goods are at their disposal. Damage incurred in shipping is the responsibility of the shipper; therefore the damage must be reported to the carrier upon receipt of merchandise.

It is the customer's responsibility to notify and submit claims with the shipper in the event that a device is damaged due to shipping. Transportation damage has to be reported to us within one day after receipt of the delivery.

Any return shipment has to be made post-paid at all times. Return shipments must be accompanied with a letter defining the reason for return shipment. Non-prepaid return shipments will be refused, unless otherwise agreed in writing.

Complaints against us must be made known in writing or by fax within 10 working days after receipt of the invoice. After this period complaints will not be handled anymore.

Complaints will only then be considered if the client has so far complied with all parts of the agreement, regardless of the agreement of which the obligation is resulting.

Description of the device

The Dap Audio DM-55 is a kick drum / high SPL bass section boundary microphone.

Features

- Tailored low frequency response
- High gain before feedback
- High dynamic range

Overview



1. Head
2. Body
3. Microphone holder
4. XLR male output

The microphone

This DM-55 kick drum mic has a more warm sound and can handle higher SPL's than the DM-20. You can use it together with the CM-95 (D1355) to be more flexible of creating your own drum sound.

Set Up and Operation

Set all volume and gain controls on your mixer, mic preamp or recording device at their minimum settings before connecting the microphone. **Make sure, the phantom power is off!**

Once the DM-55 is plugged in, move the channel fader gradually to the 0dB position adjust the input gain using your channel peak led or VU-meter.

Place the DM-55 in front of the hole in the drumhead and aim it at the place where the beater hits the rear drumhead. If you feel your sound lacks brilliance, move the DM-55 nearer to the place where the beater hits the rear drumhead. See setup example 1.

For the best results, we suggest using the DM-55 in combination with our DM-55 (D1357). Carefully cut the lows on the DM-55 channel of your mixer and cut highs on the DM-55 channel of your mixer to get the best results. See setup example 2.

Frequency and Polar Diagrams

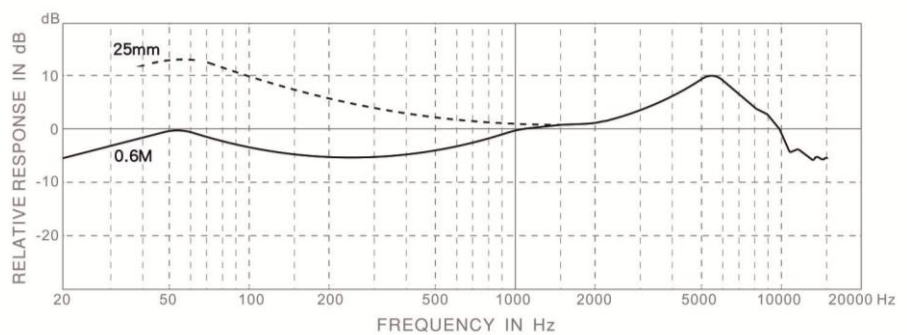
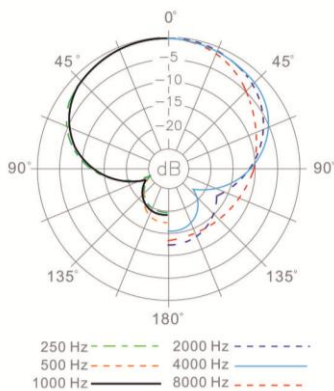

Setup example 1: Simple setup.

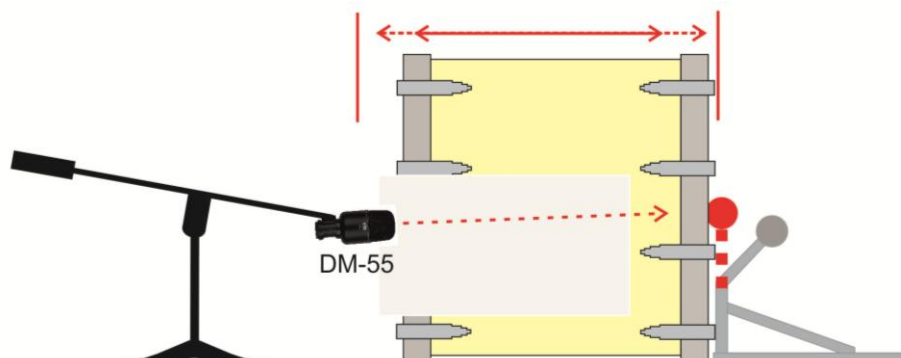

- Place the DM-55 in front of the hole in the drumhead. Aim the microphone at the place where the beater hits the rear drumhead. If you feel that your sound lacks brilliance, move the DM-55 closer to the beater.

Setup example 2: Advanced setup.

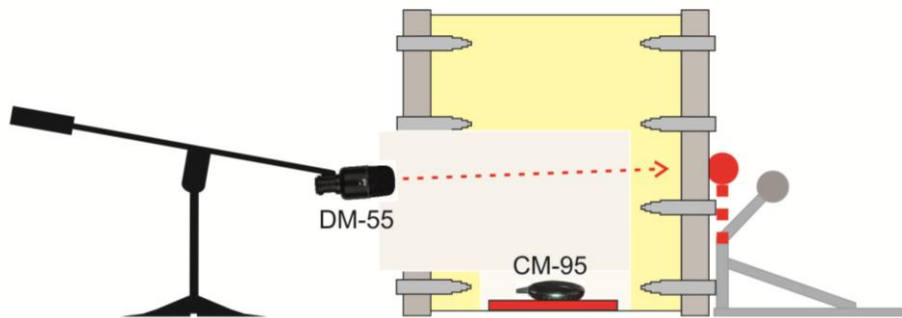

- Make sure to place the CM-95 on a cushion, piece of isolation material or other soft material to avoid contact noise.
- Place the DM-55 in front of the hole in the drumhead. Aim the microphone at the place where the beater hits the rear drumhead.
- For best results we suggest cutting the lows for the CM-95 and cutting the highs for the DM-55.

Connection Cables

Take care of your cables, always holding them by the connectors and avoiding knots and twists when coiling them: This gives the advantage of increasing their life and reliability. Periodically check your cables. A great number of problems (faulty contacts, ground hum, discharges, etc.) are caused entirely by using unsuitable or faulty cables.

Headphones

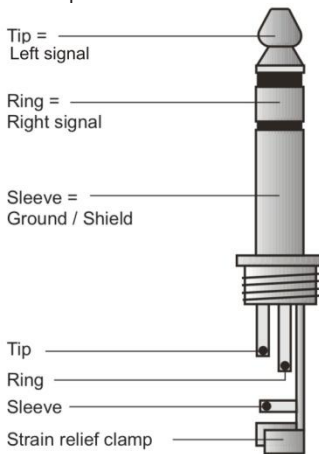

Unbalanced mono

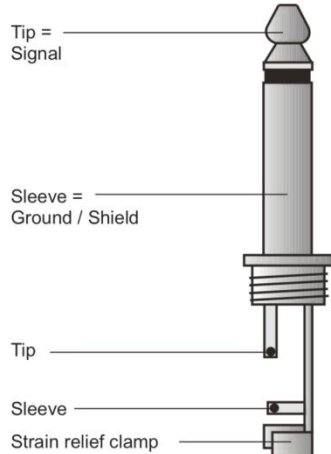

Balanced mono

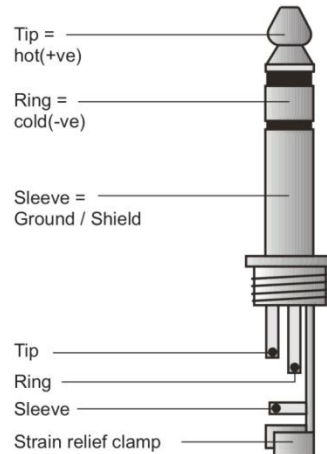

Insert

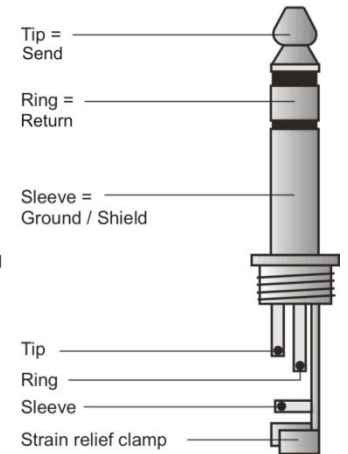

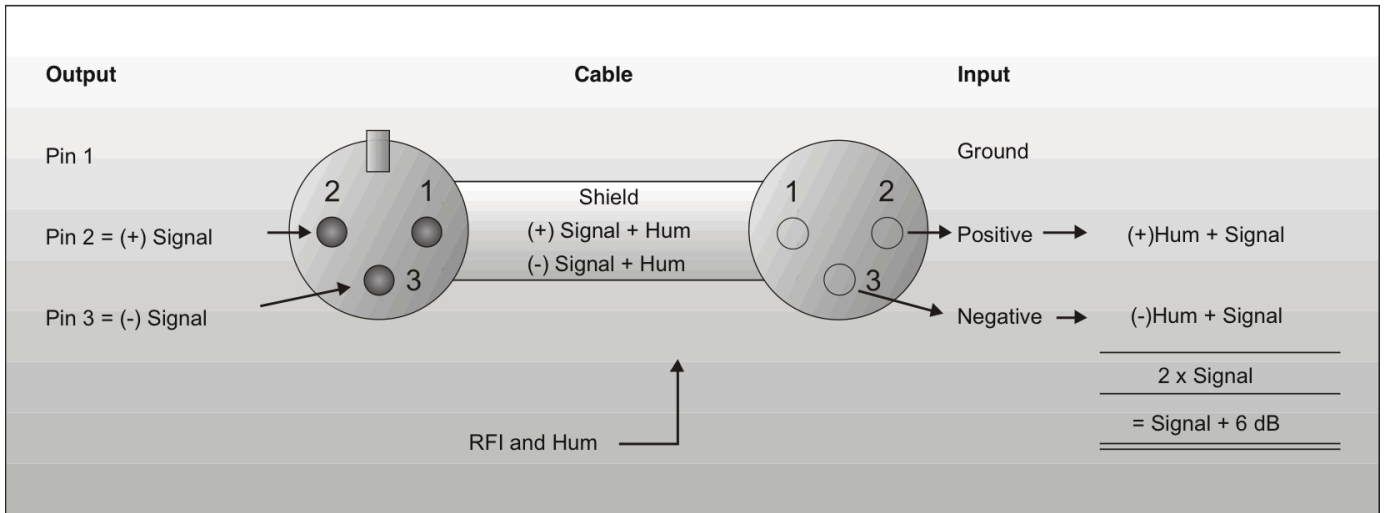

Compensation of interference with balanced connections

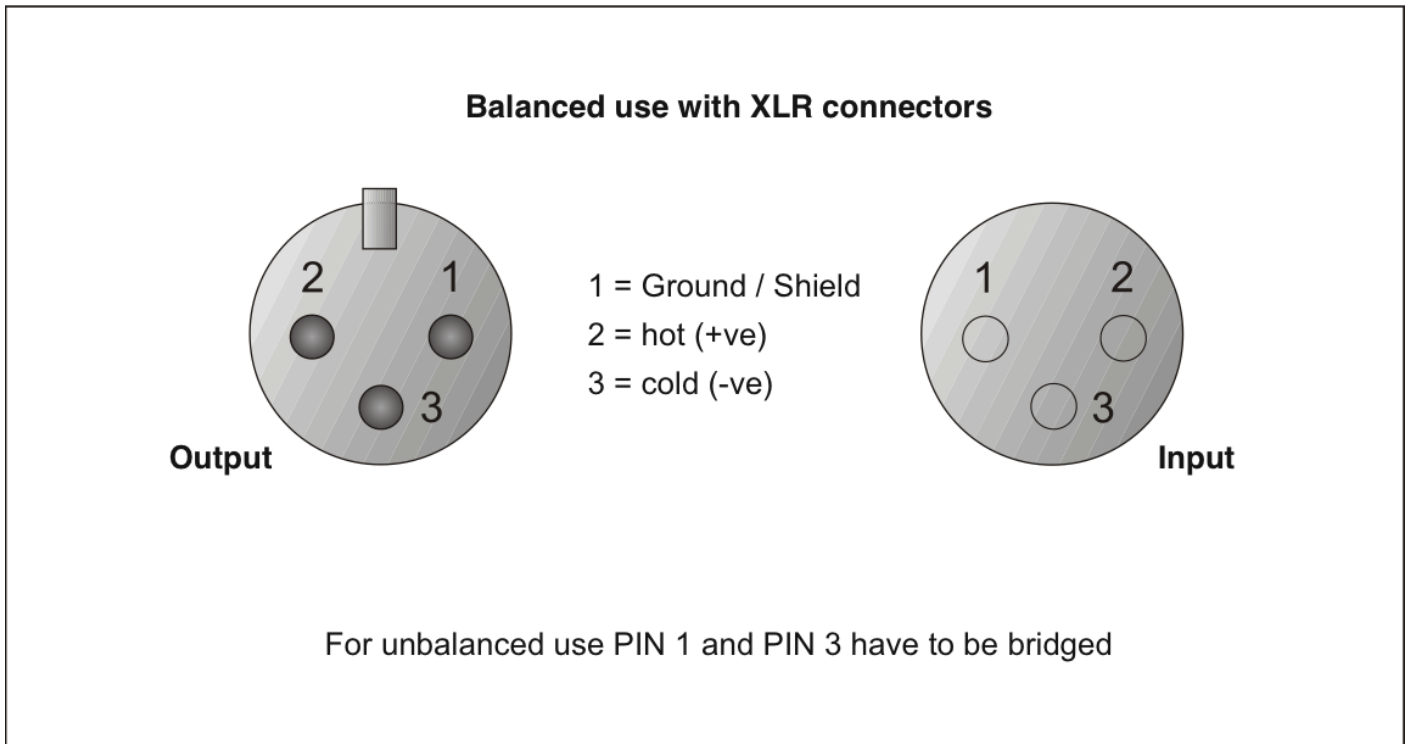

Maintenance

The DAP Audio DM-55 requires almost no maintenance. However, you should keep the unit clean. Disconnect the microphone and then wipe the cover with a damp cloth. Do not immerse in liquid. Do not use alcohol or solvents. Never immerse a microphone in water.

Product Specifications

Type:	Dynamic
Polar Pattern:	Super cardioid
Frequency Response:	30-10.000 Hz
Sensitivity:	-61 dBV/Pa (0,9 mV)
Max.SPL:	148 dB SPL
Output Impedance:	200 Ω
Power supply:	None
Connector:	3p. XLR
Accessories:	Holder with screw knob, threaded adapter, Pouch
Dimensions:	\varnothing 58x140 mm
Net Weight:	0,36 Kg



Design and product specifications are subject to change without prior notice.



Website: www.Dap-audio.info
Email: service@highlite.nl



© 2012 DapAudio.