

ENGLISH

Galaxy 360

V1

Ordercode: 45054

Table of contents

Warning	3
Safety Instructions	3
Operating Determinations	5
Rigging	5
Connection with the mains.....	6
Return Procedure	6
Claims.....	6
Description of the device	7
Frontside.....	7
Backside	8
Installation	8
Set Up and Operation	8
Control Modes.....	9
One Galaxy 360 (Built-in programs and Manual).....	9
One Galaxy 360 (Sound-control).....	9
Multiple Galaxys 360 (Master/Slave control).....	9
Multiple Galaxys 360 (DMX512 Mode).....	10
Fixture Linking.....	11
Data Cabling.....	11
Control Panel.....	12
DMX Control Mode.....	12
DMX Addressing.....	12
Menu Overview.....	13
Main Menu Options.....	14
1. DMX-512	14
2. Channel Mode.....	14
3. Run Mode.....	15
3.1. DMX Mode.....	15
3.2. Master Mode.....	15
3.3. Slave Mode.....	15
3.4. Sound Mode.....	15
3.5. Manual Mode	16
4. Functions	16
4.1. Pan Invert	16
4.2. Tilt Invert.....	17
4.3. Dimmer Curve	17
4.4. DMX Fail.....	17
4.5. Display	17
4.6. Back Light.....	18
4.7. Reset	18
4.8. Factory Sets	18
4.9. Auto Test.....	18
5. Version	18
DMX Channels	19
10 Channels	19
18 Channels	21
66 Channels	24
Maintenance	30
Replacing a Fuse	30

Troubleshooting30
 No Light30
 No Response to DMX.....31

Product Specifications32

Dimensions.....33

Notes34

Warning



**For your own safety, please read this user manual carefully
before your initial start-up!**



Unpacking Instructions

Immediately upon receiving this product, carefully unpack the carton and check the contents to ensure that all parts are present, and have been received in good condition. Notify the dealer immediately and retain packing material for inspection if any parts appear to be damaged from shipping or the carton itself shows signs of mishandling. Save the carton and all packing materials. In the event that the fixture must be returned to the factory, it is important that the fixture be returned in the original factory box and packing.

Your shipment includes:

- Showtec Galaxy 360
- 1 mounting bracket with quick locks
- Pro power connector to Schuko cable (length 1,5 m)
- Safety cable
- User manual

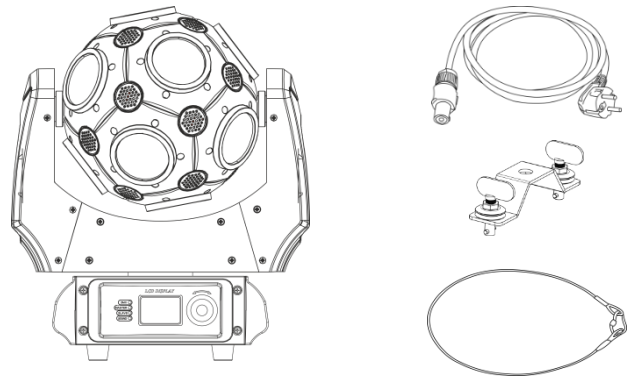

LED Expected Lifespan

LEDs gradually decline in brightness over time. HEAT is the dominant factor that leads to the acceleration of this decline. Packaged in clusters, LEDs exhibit higher operating temperatures than in ideal or singular optimum conditions. For this reason when all color LEDs are used at their fullest intensity, life of the LEDs is significantly reduced. If improving the lifespan is of higher priority, place care in providing for lower operational temperatures. This may include climatic-environmental and the reduction of overall projection intensity.



CAUTION!

**Keep this device away from rain and moisture!
Unplug mains lead before opening the housing!**



Safety Instructions

Every person involved with the installation, operation and maintenance of this device has to:

- be qualified
- follow the instructions of this manual



**CAUTION! Be careful with your operations.
With a dangerous voltage you can suffer
a dangerous electric shock when touching the wires!**



Before your initial start-up, please make sure that there is no damage caused by transportation. Should there be any, consult your dealer and do not use the device.

To maintain perfect condition and to ensure a safe operation, it is absolutely necessary for the user to follow the safety instructions and warning notes written in this manual.

Please consider that damages caused by manual modifications to the device are not subject to warranty. This device contains no user-serviceable parts. Refer servicing to qualified technicians only.

IMPORTANT:

The manufacturer will not accept liability for any resulting damages caused by the non-observance of this manual or any unauthorized modification to the device.

- Never let the power cord come into contact with other cables! Handle the power cord and all connections with the mains with particular caution!
- Never remove warning or informative labels from the unit.
- Never use anything to cover the ground contact.
- Never lift the fixture holding it by the projector-head, as the mechanics may be damaged. Always hold the fixture by the transport handles.
- Never place any material over the lens.
- Never look directly into the light source.
- Never leave any cables lying around.
- Do not insert objects into air vents.
- Do not connect this device to a dimmerpack.
- Do not switch the device on and off in short intervals, as this would reduce the device's lifespan.
- Do not touch the device's housing bare-handed during its operation. Allow the fixture to cool for at least 5 minutes before handling.
- Do not shake the device. Avoid brute force when installing or operating the device.
- Only use device indoors, avoid contact with water or other liquids.
- Only operate the fixture after having checked if the housing is firmly closed and all screws are tightly fastened.
- Only operate the device after having familiarized with its functions.
- Avoid flames and do not put close to flammable liquids or gases.
- Always keep case closed while operating.
- Always allow free air space of at least 50 cm around the unit for ventilation.
- Always disconnect power from the mains, when device is not used or before cleaning! Only handle the power cord by the plug. Never pull out the plug by tugging the power cord.
- Make sure that the device is not exposed to extreme heat, moisture or dust.
- Make sure that the available voltage is not higher than stated on the rear panel.
- Make sure that the power cord is never crimped or damaged. Check the device and the power cord from time to time.
- If the lens is obviously damaged, it has to be replaced to prevent its functions from being impaired, due to cracks or deep scratches.
- If device was dropped or struck, disconnect mains power supply immediately. Have a qualified engineer inspect for safety before operating.
- If the device has been exposed to drastic temperature fluctuation (e.g. after transportation), do not switch it on immediately. The arising condensation water might damage your device. Leave the device switched off until it has reached room temperature.
- If your Showtec device fails to work properly, discontinue use immediately. Pack the unit securely (preferably in the original packing material), and return it to your Showtec dealer for service.
- For adult use only. Device must be installed out of reach of children. Never leave the unit running unattended.
- Never attempt to bypass the thermostatic switch or fuses.
- For replacement, use fuses of same type and rating only.
- The user is responsible for correct positioning and operating of the Galaxy 360. The manufacturer will not accept liability for damages caused by the misuse or incorrect installation of this device.
- This device falls under protection class I. Therefore it is essential to connect the yellow/green conductor to earth.
- Repairs, servicing and electrical connection must be carried out by a qualified technician.
- WARRANTY: Till one year after date of purchase.



CAUTION! Eyedamages!!!
Avoid looking directly into the lightsource!!!
(meant especially for epileptics)!!!



Operating Determinations

- This device is not designed for permanent operation. Regular operation breaks will ensure that the device will serve you for a long time without defects.
- The minimum distance between light-output and the illuminated surface must be bigger than 1 meter.
- The maximum ambient temperature $t_a = 40^{\circ}\text{C}$ must never be exceeded.
- The relative humidity must not exceed 50 % with an ambient temperature of 40°C .
- If this device is operated in any other way than the one described in this manual, the product may suffer damages and the warranty becomes void.
- Any other operation may lead to dangers like short-circuit, burns, electric shock, crash etc.

You endanger your own safety and the safety of others!

Rigging

Please follow the European and national guidelines concerning rigging, trussing and all other safety issues.

Do not attempt the installation yourself!

Always let the installation be carried out by an authorized dealer!

Procedure:

- If the Galaxy 360 is lowered from the ceiling or high joists, professional trussing systems have to be used.
- Use a clamp to mount the Galaxy 360, with the mounting bracket, to the trussing system.
- The Galaxy 360 must never be fixed swinging freely in the room.
- The installation must always be secured with a safety attachment, e.g. an appropriate safety net or safety cable.
- When rigging, derigging or servicing the Galaxy 360, always make sure, that the area below the installation site is secured and that there are not any unauthorized people around.

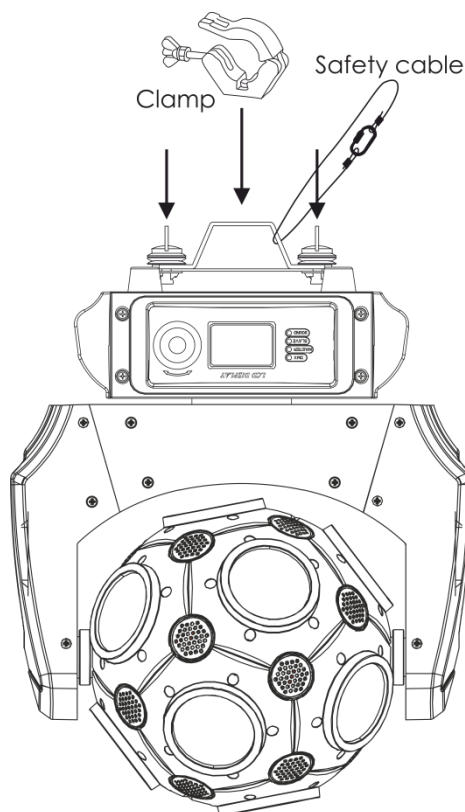

The Galaxy 360 can be placed on a flat stage floor or mounted to any kind of truss by a clamp.

Improper installation can cause serious injuries and/or damage of property!

Connection with the mains

Connect the device to the mains with the power plug.
Always check if the right color cable is connected to the right place.

International	EU Cable	UK Cable	US Cable	Pin
L	BROWN	RED	YELLOW/COPPER	PHASE
N	BLUE	BLACK	SILVER	NEUTRAL
	YELLOW/GREEN	GREEN	GREEN	PROTECTIVE GROUND

Make sure that the device is always connected properly to the earth!

Improper installation can cause serious damage to people and property!



Return Procedure



Returned merchandise must be sent prepaid and in the original packing, call tags will not be issued. Package must be clearly labeled with a Return Authorization Number (RMA number). Products returned without an RMA number will be refused. Highlite will not accept the returned goods or any responsibility. Call Highlite 0031-455667723 or mail aftersales@highlite.nl and request an RMA prior to shipping the fixture. Be prepared to provide the model number, serial number and a brief description of the cause of the return. Be sure to properly pack fixture as any shipping damage resulting from inadequate packaging is the customer's responsibility. Highlite reserves the right to use its own discretion to repair or replace product(s). As a suggestion, proper UPS packing or double-boxing is always a safe method to use.

Note: If you are given an RMA number, please include the following information on a piece of paper inside the box:

- 01) Your name.
- 02) Your address.
- 03) Your phone number.
- 04) A brief description of the symptoms.

Claims

The client has the obligation to check the delivered goods immediately upon delivery for any shortcomings and/or visible defects, or perform this check after our announcement that the goods are at their disposal. Damage incurred in shipping is the responsibility of the shipper; therefore the damage must be reported to the carrier upon receipt of merchandise.

It is the customer's responsibility to notify and submit claims with the shipper in the event that the fixture is damaged due to shipping. Transportation damage has to be reported to us within one day after receipt of the delivery.

Any return shipment has to be made post-paid at all times. Return shipments must be accompanied with a letter defining the reason for return shipment. Non-prepaid return shipments will be refused, unless agreed otherwise in writing.

Complaints against us must be made known in writing or by fax within 10 working days after receipt of the invoice. After this period, complaints will not be handled anymore.

Complaints will only be considered if the client has so far complied with all parts of the agreement, regardless of the agreement of which the obligation is resulting.

Description of the device

Features

The Showtec Galaxy 360 is a moving head with high output and great effects.

- Input voltage: 100~240V AC
- Power consumption: 190W
- Light source: 12 x 9W RGBW LED
- Channels: 10, 18, 66 channels
- Beam Angle: 4°
- Dimmer: 0-100%
- Strobe: 0-20Hz
- Dimmer curves: Linear, Square, I-Square, S curve
- Pan: 0-540° & continuous
- Ball: 0-360° & continuous
- Pan/Tilt resolution: 16 bit
- Onboard: Display including gravity sensor
- Control mode: DMX, Auto, Manual, Sound, Master/Slave
- Data connections: 3-pin/5-pin XLR IN/OUT
- Power connections: Pro Power connector IN/OUT
- Housing: Black metal & flame-retardant plastic
- Fuse: 3A/250V
- Dimensions: 335 x 145 x 395 mm (LxWxH)
- Weight: 7,2 kg

Frontside

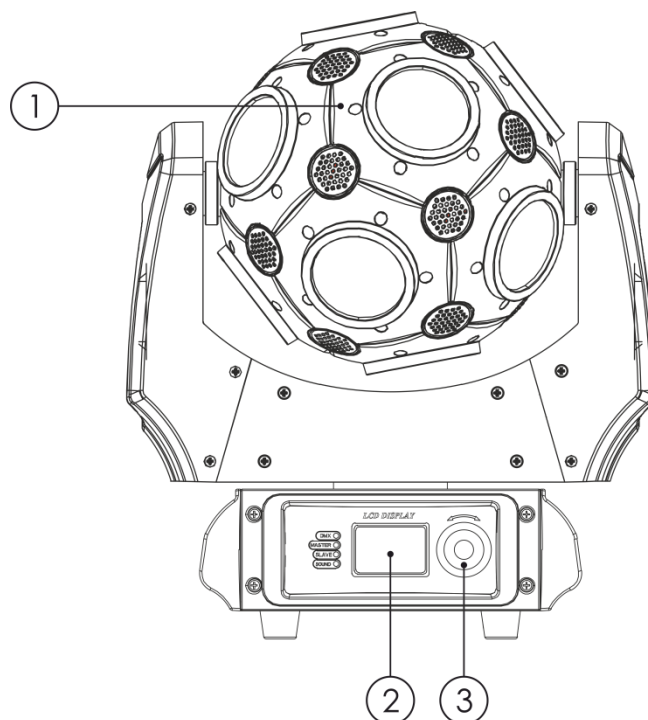

- 01) Lens
02) LCD display + menu buttons
03) Menu control

Fig. 01

Backside

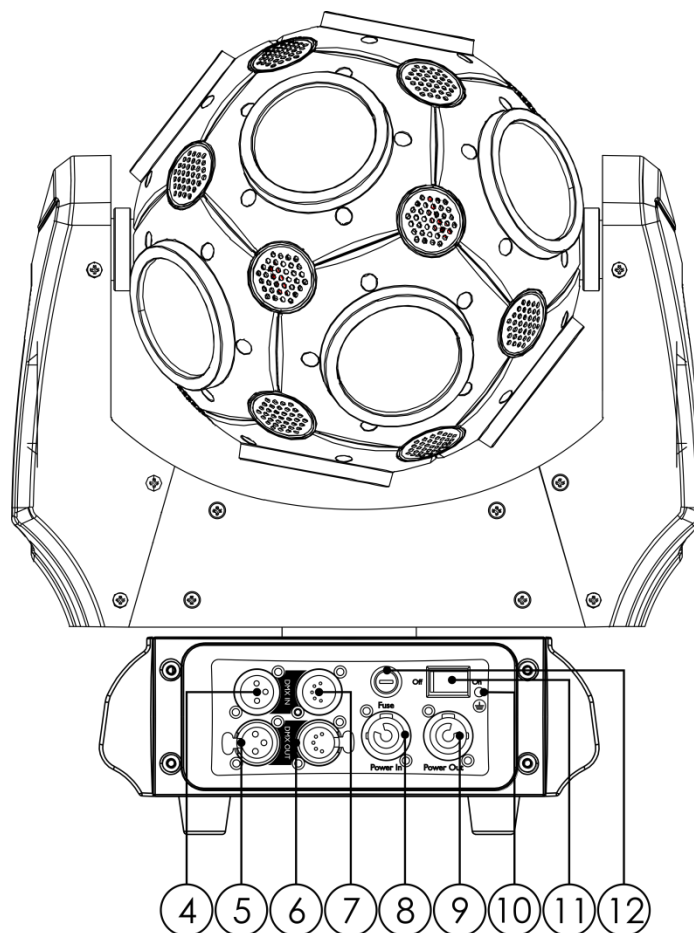

Fig. 02

- 04) 3-pin DMX signal connector IN
- 05) 3-pin DMX signal connector OUT
- 06) 5-pin DMX signal connector OUT
- 07) 5-pin DMX signal connector IN
- 08) Pro Power connector 100-240V IN
- 09) Pro Power connector 100-240V OUT
- 10) Ground/earth connection
- 11) Power switch ON/OFF
- 12) Fuse 3A/250V

Installation

Remove all packing materials from the Galaxy 360.

Check that all foam and plastic padding is removed. Connect all cables.

Do not supply power before the whole system is set up and connected properly.

Always disconnect from electric mains power supply before cleaning or servicing.

Damages caused by non-observance are not subject to warranty.

Set Up and Operation

Follow the directions below, as they pertain to your preferred operation mode.

Before plugging the unit in, always make sure that the power supply matches the product specification voltage. Do not attempt to operate a 120V specification product on 230V power, or vice versa.

Connect the device to the main power supply.

Control Modes

There are 5 modes:

- Built-in programs (Master mode)
- Sound-controlled
- Manual
- Master/Slave
- DMX-512 (10CH, 18CH, 66CH)

One Galaxy 360 (Built-in programs and Manual)

- 01) Fasten the effect light onto firm trussing. Leave at least 0,5 meter on all sides for air circulation.
- 02) Always use a safety cable (ordercode 70140 / 70141).
- 03) Plug the end of the electric mains power cord into a proper electric power supply socket.
- 04) When the Galaxy 360 is not connected by a DMX cable, it functions as a stand-alone device. Please see pages 15 and 16 for more information about the Built-in programs (Master mode) and Manual mode.

One Galaxy 360 (Sound-control)

- 01) Fasten the effect light onto firm trussing. Leave at least 0,5 meter on all sides for air circulation.
- 02) Always use a safety cable (ordercode 70140 / 70141).
- 03) Plug the end of the electric mains power cord into a proper electric power supply socket.
- 04) Turn on the music. If the device is set to sound-control, then the Galaxy 360 will react to the beat of the music. Please see page 15 for more information about the sound-control options.

Multiple Galaxy 360 (Master/Slave control)

- 01) Fasten the effect light onto firm trussing. Leave at least 0,5 meter on all sides for air circulation.
- 02) Always use a safety cable (ordercode 70140 / 70141).
- 03) Use a 3-pin/5-pin XLR cable to connect the Galaxy 360 and other devices.

The pins:



1. Earth
2. Signal (-)
3. Signal (+)

- 04) Link the units as shown in (Fig. 03), connect a DMX signal cable from the first unit's DMX "out" socket to the second unit's "in" socket. Repeat this process to link the second and third units. You can use the same functions on the master device as described on pages 15 and 16 (Built-in programs, Manual and Sound-control). This means you can set your desired operation mode on the master device and all slave devices will react the same as the master device.

Multiple Galaxy 360 (Master/Slave control)

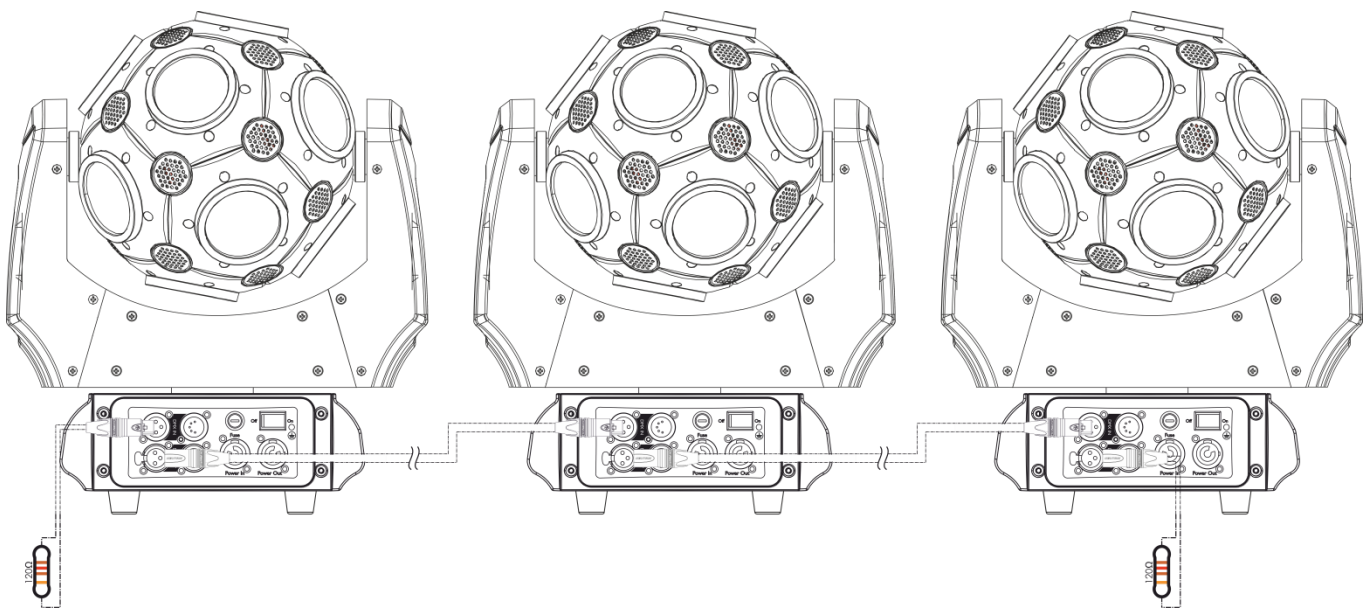
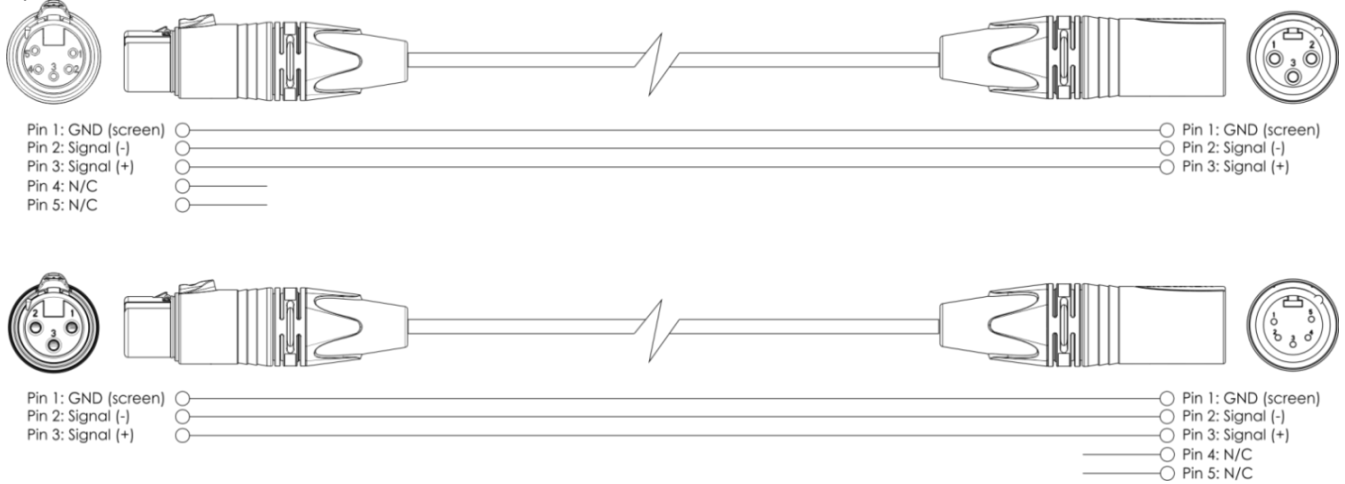

Fig. 03

Multiple Galaxys 360 (DMX512 Mode)

- 01) Fasten the effect light onto firm trussing. Leave at least 0,5 meter on all sides for air circulation.
- 02) Always use a safety cable (ordercode 70140 / 70141).
- 03) Plug the end of the electric mains power cord into a proper electric power supply socket.
- 04) Use a 3-pin/5-pin XLR cable to connect the Galaxy and other devices.



- 05) Link the units as shown in (Fig. 04), Connect a DMX signal cable from the first unit's DMX "out" socket to the second unit's "in" socket. Repeat this process to link the second and third units.
- 06) Supply electric power: Plug electric mains power cords into each unit's Pro Power socket, then plug the other end of the mains power cord into proper electric power supply sockets, starting with the first unit. Do not supply power before the whole system is set up and connected properly.

Multiple Galaxys 360 DMX Set Up

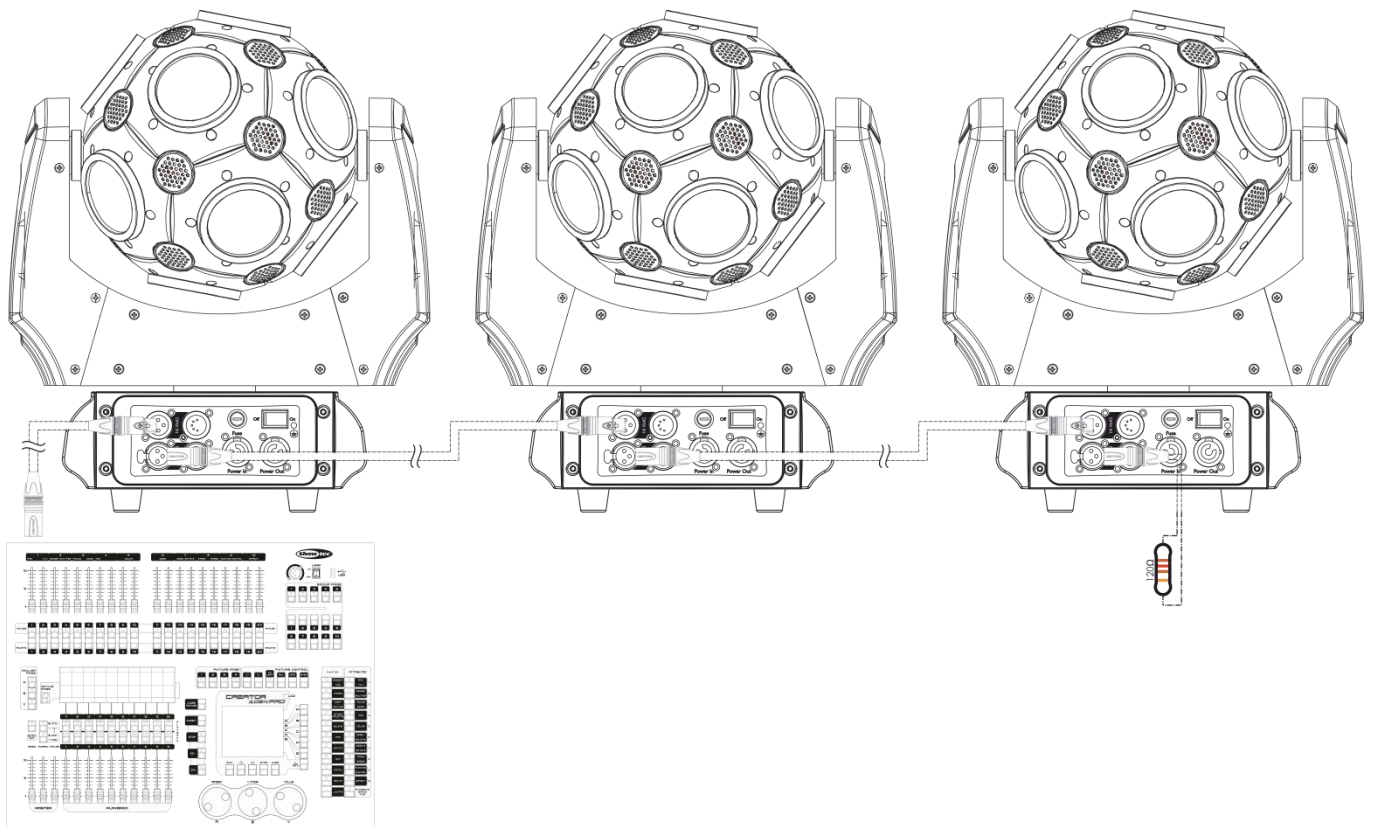



Fig. 04

Note: Link all cables before connecting electric power!

Fixture Linking

You will need a serial data link to run light shows of one or more fixtures using a DMX-512 controller or to run synchronized shows on two or more fixtures set to a master/slave operating mode. The combined number of channels required by all the fixtures on a serial data link determines the number of fixtures the data link can support.

Important: Fixtures on a serial data link must be daisy-chained in a single line. To comply with the EIA-485 standard, no more than 30 devices should be connected on one data link. Connecting more than 30 fixtures on one serial data link without the use of a DMX optically isolated splitter may result in deterioration of the digital DMX signal.

 Maximum recommended DMX data link distance: 100 meters
 Maximum recommended number of fixtures on a DMX data link: 30 fixtures
 Maximum recommended number of fixtures on a power link: 5 @ 110V
 Maximum recommended number of fixtures on a power link: 10 @ 240V

Data Cabling

To link fixtures together you must obtain data cables. You can purchase DAP Audio certified DMX cables directly from a dealer/distributor or construct your own cable. If you choose to create your own cable please use data-grade cables that can carry a high quality signal and are less prone to electromagnetic interference.

DAP Audio DMX Data Cables

- DAP Audio Basic microphone cable for allround use. bal. XLR/M 3-pin > XLR/F 3-pin. **Ordercode** FL01150 (1,5 m), FL013 (3 m), FL016 (6 m), FL0110 (10 m), FL0115 (15 m), FL0120 (20 m).
- DAP Audio X-type data cable XLR/M 3-pin > XLR/F 3-pin. **Ordercode** FLX0175 (0,75 m), FLX01150 (1,5 m), FLX013 (3 m), FLX016 (6 m), FLX0110 (10 m).
- DAP Audio cable for the demanding user with exceptional audio-qualities and connector made by Neutrik®. **Ordercode** FL71150 (1,5 m), FL713 (3 m), FL716 (6 m), FL7110 (10 m).
- DAP Audio cable for the demanding user with exceptional audio-qualities and connector made by Neutrik®. **Ordercode** FL7275 (0,75 m), FL72150 (1,5 m), FL723 (3 m), FL726 (6 m), FL7210 (10 m).
- DAP Audio 110 Ohm cable with digital signal transmission. **Ordercode** FL0975 (0,75 m), FL09150 (1,5 m), FL093 (3 m), FL096 (6 m), FL0910 (10 m), FL0915 (15 m), FL0920 (20 m).
- DAP Audio DMX adapter: 3-pin/5-pin. **Ordercode** FLA30.

Control Panel

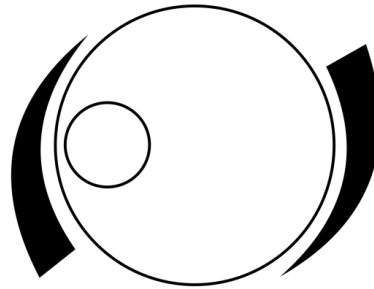

Press and turn the control to navigate through the menu options

Fig. 05

DMX Control Mode

The fixtures are individually addressed on a data-link and connected to the controller. When a DMX signal is present, the DMX LED will blink.

The fixtures respond to the DMX signal from the controller. (When you select the DMX address and save it, the controller will display the saved DMX address the next time.)

DMX Addressing

The control panel on the front side of the base allows you to assign the DMX fixture address, which is the first channel from which the Galaxy 360 will respond to the controller.

Please note when you use the controller, the unit has **66** channels.

When using multiple Galaxys, make sure that you set the DMX addresses right.

Therefore, the DMX address of the first Galaxy should be **1(d001)**; the DMX address of the second Galaxy should be **1+66=67 (d067)**; the DMX address of the third Galaxy should be **67+66=133 (d133)**, etc. Please, make sure that you do not have any overlapping channels in order to control each Galaxy correctly. If two or more Galaxys are addressed similarly, they will work similarly.

Controlling:

After having addressed all Galaxy fixtures, you may now start operating these via your lighting controller.

Note: After switching on, the Galaxy 360 will automatically detect whether DMX 512 data is received or not. If there is no data received at the DMX input, the DMX LED will not blink.

The problem may be:

- The XLR cable from the controller is not connected with the input of the Galaxy 360.
- The controller is switched off or defective, the cable or connector is defective, or the signal wires are swapped in the input connector.

Note: It is necessary to insert an XLR termination plug (with 120 Ohm) in the last fixture in order to ensure proper transmission on the DMX data link.

Display Off after 40 seconds

When the MENU control is neither pressed or turned for 40 seconds, the display will show the default screen. To return to the main menu, you have to press or turn the MENU control **(03)**.

Once you have pressed or turned the control, the display will show the main menu screen.

Menu Overview

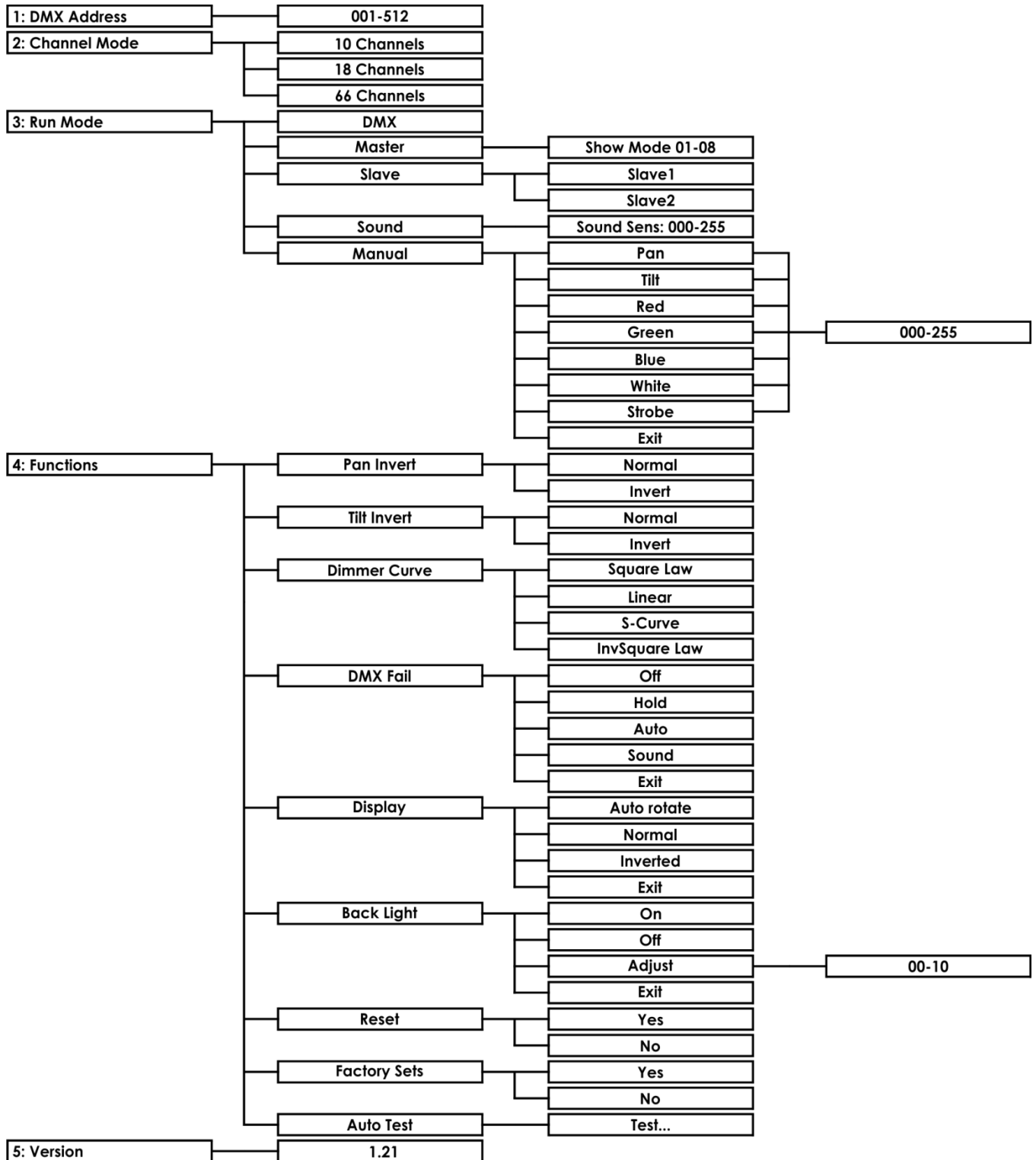

Main Menu Options

There are 5 menu modes:

- 1. DMX-512
- 2. Channel Mode
- 3. Run Mode
- 4. Functions
- 5. Version

1. DMX-512

With this menu you can adjust the device's DMX settings.

01) When in main menu, **turn** the MENU control **(03)** until the display shows:



1) DMX Address
2) Channel Mode
3) Run Mode
4) Functions

02) **Press** the MENU control **(03)** to enter the menu.

03) The display will show:

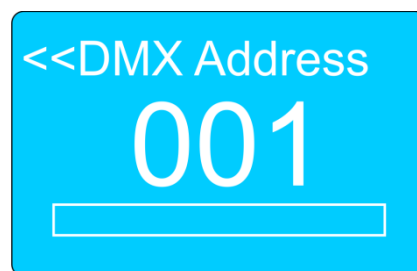

<<DMX Address
001

04) **Turn** the MENU control **(03)** to set the desired DMX address.

05) The adjustment range is between 001-512.

06) **Press** the MENU control **(03)** to confirm the DMX address.

2. Channel Mode

01) When in main menu, **turn** the MENU control **(03)** until the display shows:



1) DMX Address
2) Channel Mode
3) Run Mode
4) Functions

02) **Press** the MENU control **(03)** to enter the menu.

03) **Turn** the MENU control **(03)** to toggle between the 3 available channel modes:

- 10 channels
- 18 channels
- 66 channels

04) **Press** the MENU control **(03)** to choose the desired channel mode.

05) For more information about the DMX channels and their functions, see pages 19-29.

3. Run Mode

01) When in main menu, **turn** the MENU control **(03)** until the display shows:



1) DMX Address
2) Channel Mode
3) Run Mode
4) Functions

02) **Press** the MENU control **(03)** to enter the menu.

03) **Turn** the MENU control **(03)** to toggle between the 5 available modes:

- DMX
- Master
- Slave
- Sound
- Manual

04) **Press** the MENU control **(03)** to open the desired mode.

3.1. DMX Mode

01) **Press** the MENU control **(03)** to activate DMX mode.

3.2. Master Mode

01) **Turn** the MENU control **(03)** to choose one of 8 built-in auto shows:

- Showmode 01 – Showmode 08

02) **Press** the MENU control **(03)** to confirm your choice.

03) The device will now run the desired auto show.

3.3. Slave Mode

01) **Turn** the MENU control **(03)** to toggle between the 2 slave functions:

- Slave1 (normal slave mode)
- Slave2 (mirror slave mode)

03) **Press** the MENU control **(03)** to confirm your preferred slave mode.

04) The device is now operating in slave mode and it will react the same as the master device (Slave1), or it will mirror the actions of the master device (Slave2).

3.4. Sound Mode

01) **Press** the MENU control **(03)** to enter the menu.

02) The display will show the following screen:

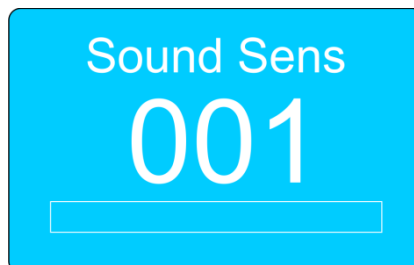

Sound Sens
001

03) **Turn** the MENU control **(03)** to adjust the sound sensitivity. The adjustment range is between 000-255, from low to high sensitivity.

04) **Press** the MENU control **(03)** to confirm.

3.5. Manual Mode

- 01) **Turn** the MENU control **(03)** to toggle between the 7 available functions:
 - Pan (Pan adjustment)
 - Tilt (Tilt adjustment)
 - Red (Red LED intensity)
 - Green (Green LED intensity)
 - Blue (Blue LED intensity)
 - White (White LED intensity)
 - Strobe (Strobe frequency)
- 02) **Press** the MENU control **(03)** to select the desired function.
- 03) **Turn** the MENU control **(03)** to set the value. The adjustment range of each function is between 000-255.
- 04) **Press** the MENU control **(03)** to save the changes.
- 05) **Turn** the MENU control **(03)** to choose Exit and press the MENU control **(03)** to return to the previous menu.

4. Functions

- 01) When in main menu, **turn** the MENU control **(03)** until the display shows:



- 02) **Press** the MENU control **(03)** to enter the menu.
- 03) **Turn** the MENU control **(03)** to toggle between the 9 available functions:
 - Pan Invert
 - Tilt Invert
 - Dimmer Curve
 - DMX Fail
 - Display
 - Back Light
 - Reset
 - Factory Sets
 - Auto Test

- 04) Press the MENU control **(03)** to open the desired menu.

4.1. Pan Invert

- 01) **Turn** the MENU control **(03)**, choose Normal and **press** the MENU control **(03)** to deactivate pan inversion.
- 02) **Turn** the MENU control **(03)**, choose Invert and **press** the MENU control **(03)** to activate pan inversion.
- 03) **Press** the MENU control **(03)** to confirm the changes.

4.2. Tilt Invert

- 01) **Turn** the MENU control **(03)**, choose Normal and **press** the MENU control **(03)** to deactivate tilt inversion.
- 02) **Turn** the MENU control **(03)**, choose Invert and **press** the MENU control **(03)** to activate tilt inversion.
- 03) **Press** the MENU control **(03)** to confirm the changes.

4.3. Dimmer Curve

- 01) **Turn** the MENU control **(03)** to toggle between the 4 available modes:
 - Square Law
 - Linear
 - S-curve
 - Inv. Square Law

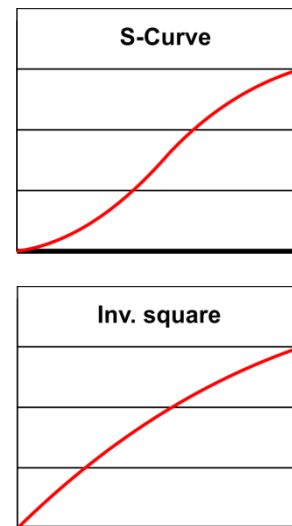
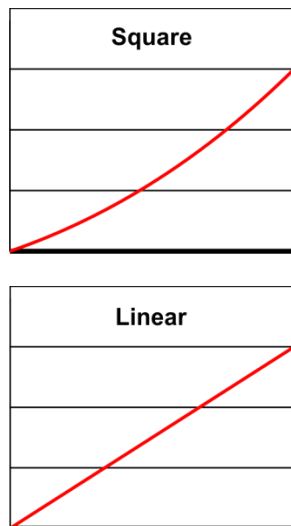

- 02) **Press** the MENU control **(03)** to confirm the mode of your choice.

4.4. DMX Fail

With this menu you can determine the behaviour of the Galaxy in case of DMX failure.

- 01) **Turn** the MENU control **(03)** to toggle between the 4 available modes:
 - Off (DMX signal lost, device stops)
 - Hold (DMX signal lost, device will remember the last successfully received DMX signal and will continue using it until DMX signal reception is restored)
 - Auto (DMX signal lost, device starts an auto program)
 - Sound (DMX signal lost, device becomes sound active)
- 02) **Press** the MENU control **(03)** to confirm your choice.

4.5. Display

- 01) **Press** the MENU control **(03)** to enter the menu.
- 02) **Turn** the MENU control **(03)** to toggle between the 3 options:
 - Auto Rotate (Display flips accordingly to the position of the fixture)
 - Normal
 - Inverted (horizontal flip)
- 03) **Press** the MENU control **(03)** to confirm your choice.

4.6. Back Light

- 01) **Turn** the MENU control **(03)** to toggle between the 3 options:
 - ON (Display continuously ON)
 - OFF (Display turns OFF after 15 seconds)
 - Adjust (Display brightness)
- 02) **Turn** the MENU control **(03)** to choose Adjust and **press** the MENU control **(03)** to enter the menu.
- 03) The display will show:



- 04) **Turn** the MENU control **(03)** to adjust brightness. The adjustment range is between 00-10, from dark to brightest.
- 05) **Press** the MENU control **(03)** to confirm the changes.

4.7. Reset

- 01) **Turn** the MENU control **(03)**, choose Yes and **press** the MENU control **(03)** to reset the Galaxy.
- 02) **Turn** the MENU control **(03)**, choose No and **press** the MENU control **(03)** to cancel the reset function.

4.8. Factory Sets

- 01) **Turn** the MENU control **(03)**, choose Yes and **press** the MENU control **(03)** to restore the factory default settings.
- 02) **Turn** the MENU control **(03)**, choose No and **press** the MENU control **(03)** to return to the main menu.

4.9. Auto Test

- 01) **Turn** the MENU control **(03)**, choose Test and **press** the MENU control **(03)** to perform a full test of all the available functions.
- 02) **Turn** the MENU control **(03)**, choose Exit and **press** the MENU control **(03)** to return to the main menu.

5. Version

- 01) When in main menu, **turn** the MENU control **(03)** until the display shows:

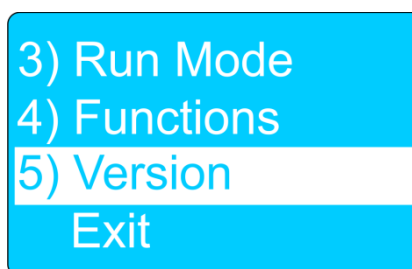

- 02) **Press** the MENU control **(03)** to enter the menu.
- 03) The display will show the current software version, installed on the Galaxy:



DMX Channels

10 Channels

Channel 1 – Horizontal movement (Pan)

Push the slider up, in order to move head horizontally (PAN).

Gradual head adjustment, between 0-255. The head can be turned by 540° and stopped at any position you wish.

Channel 2 –Vertical movement (Tilt)

Push the slider, up in order to move head vertically (TILT).

Gradual head adjustment, between 0-255. The head can be turned by 360° and stopped at any position you wish.

Channel 3 – Continuous pan

0-15	No function
16-135	Clockwise rotation, from slow to fast
136-255	Counterclockwise rotation, from slow to fast

Channel 4 – Continuous tilt

0-15	No function
16-135	Clockwise rotation, from slow to fast
136-255	Counterclockwise rotation, from slow to fast

Channel 5 – Master Dimmer intensity

0-255	From dark to brightest 0-100%
-------	-------------------------------

Channel 6 – Strobe (CH5 must be set between 001-255 and CH7 between 8-255)

0-10	Off
11-128	Random strobe intensity, from low to high frequency
129-255	Linear strobe intensity, from low to high frequency

Channel 7 – Color presets (CH5 must be set between 001-255)

0-7	No function
8-13	Color 1 (R255, G000, B000, W000)
14-20	Color 2 (R255, G000, B000, W100)
21-27	Color 3 (R255, G000, B000, W200)
28-34	Color 4 (R255, G050, B000, W000)
35-41	Color 5 (R255, G150, B000, W000)
42-48	Color 6 (R255, G255, B000, W000)
49-55	Color 7 (R255, G255, B000, W075)
56-62	Color 8 (R000, G255, B000, W255)
63-69	Color 9 (R000, G255, B000, W150)
70-76	Color 10 (R000, G255, B000, W050)
77-83	Color 11 (R000, G255, B000, W000)
84-90	Color 12 (R000, G255, B050, W000)
91-97	Color 13 (R000, G255, B150, W000)
98-104	Color 14 (R000, G255, B255, W000)
105-111	Color 15 (R000, G255, B255, W075)
112-118	Color 16 (R000, G255, B255, W150)
119-125	Color 17 (R000, G100, B255, W255)
126-132	Color 18 (R000, G000, B255, W100)
133-139	Color 19 (R000, G000, B255, W050)
140-146	Color 20 (R000, G000, B255, W000)
147-153	Color 21 (R075, G000, B255, W000)
154-160	Color 22 (R160, G000, B255, W000)

161-167	Color 23 (R255, G000, B255, W000)
168-174	Color 24 (R255, G000, B175, W000)
175-181	Color 25 (R255, G000, B100, W000)
182-188	Color 26 (R255, G000, B100, W050)
189-195	Color 27 (R255, G000, B025, W050)
196-202	Color 28 (R255, G000, B025, W025)
203-209	Color 29 (R255, G000, B025, W000)
210-216	Color 30 (R000, G000, B000, W255)
217-223	Color 31 (R075, G075, B000, W255)
224-230	Color 32 (R000, G000, B100, W255)
231-255	Color 33 (R255, G255, B255, W255)

Channel 8 – Color running (CH5 and CH9 must be set between 001-255)

0-15	No function
016-023	Jump 1
024-031	Jump2(pixel effect)
032-039	Jump 3
040-047	Jump4(pixel effect)
048-055	Jump 5
056-063	Jump6(pixel effect)
064-071	Jump 7
072-079	Jump8(pixel effect)
080-087	Jump9
088-095	Jump10(pixel effect)
096-103	Jump11
104-111	Jump12(pixel effect)
112-119	Jump13
120-127	Jump14(pixel effect)
128-135	Jump15
136-143	Jump16(pixel effect)
144-151	Fade 1
152-159	Fade 2
160-167	Fade 3
168-175	Fade 4
176-183	Fade 5
184-191	Fade 6
192-199	Fade 7
200-207	Rainbow 1(pixel effect)
208-215	Rainbow 2(pixel effect)
216-223	Blue Red fade(pixel effect)
224-231	Blue Green fade(pixel effect)
232-255	Yellow Red fade(pixel effect)

Note: Color running (CH8) overrules color presets (CH7).

Channel 9 – Speed color running

0-255	Gradual speed adjustment, from slow to fast
-------	---

Channel 10 – Functions (CH5 must be set between 001-255 )

0-5	No function
6-10	Show 1
11-20	Show 2
21-30	Show 3
31-40	Show 4
41-50	Show 5
51-60	Show 6
61-70	Show 7
71-80	Show 8
81-90	Slave 1
91-96	Slave 2
97-160	Sound sensitivity, from low sensitivity to high sensitivity
161-170	Pan inversion
171-180	Tilt inversion
181-190	Pan normal
191-200	Tilt normal
201-220	Pan/Tilt blackout ON
221-240	Reset after 5 seconds
241-255	No function

Note: The shows (CH10) overrule color presets (CH7) and color running (CH8).

18 Channels**Channel 1 – Horizontal movement (Pan)**

Push the slider up, in order to move head horizontally (PAN).

Gradual head adjustment, between 0-255. The head can be turned by 540° and stopped at any position you wish.

Channel 2 – Pan fine 16 bit**Channel 3 –Vertical movement (Tilt)**

Push the slider, up in order to move head vertically (TILT).

Gradual head adjustment, between 0-255. The head can be turned by 360° and stopped at any position you wish.

Channel 4 –Tilt fine 16 bit**Channel 5 – Pan/Tilt speed**

0-255	From maximum speed (0) to minimum speed (255)
-------	---

Channel 6 – Continuous pan

0-15	No function
16-135	Clockwise rotation, from slow to fast
136-255	Counterclockwise rotation, from slow to fast

Channel 7 – Continuous tilt

0-15	No function
16-135	Clockwise rotation, from slow to fast
136-255	Counterclockwise rotation, from slow to fast

Channel 8 – Master Dimmer intensity

0-255	From dark to brightest 0-100%
-------	-------------------------------

Channel 9 – Linear Strobe**(CH8 and CH15, CH16, CH17 or CH18 must be set between 001-255 and CH11 between 8-255 )**

0-10	Off
11-255	Linear strobe intensity, from low to high frequency

Channel 10 – Random Strobe**(CH8 and CH15, CH16, CH17 or CH18 must be set between 001-255 and CH11 between 8-255 )**

0-10	Off
11-255	Random strobe intensity, from low to high frequency

Channel 11 – Color presets (CH8 must be set between 001-255 )

0-7	No function
8-13	Color 1 (R255, G000, B000, W000)
14-20	Color 2 (R255, G000, B000, W100)
21-27	Color 3 (R255, G000, B000, W200)
28-34	Color 4 (R255, G050, B000, W000)
35-41	Color 5 (R255, G150, B000, W000)
42-48	Color 6 (R255, G255, B000, W000)
49-55	Color 7 (R255, G255, B000, W075)
56-62	Color 8 (R000, G255, B000, W255)
63-69	Color 9 (R000, G255, B000, W150)
70-76	Color 10 (R000, G255, B000, W050)
77-83	Color 11 (R000, G255, B000, W000)
84-90	Color 12 (R000, G255, B050, W000)
91-97	Color 13 (R000, G255, B150, W000)
98-104	Color 14 (R000, G255, B255, W000)
105-111	Color 15 (R000, G255, B255, W075)
112-118	Color 16 (R000, G255, B255, W150)
119-125	Color 17 (R000, G100, B255, W255)
126-132	Color 18 (R000, G000, B255, W100)
133-139	Color 19 (R000, G000, B255, W050)
140-146	Color 20 (R000, G000, B255, W000)
147-153	Color 21 (R075, G000, B255, W000)
154-160	Color 22 (R160, G000, B255, W000)
161-167	Color 23 (R255, G000, B255, W000)
168-174	Color 24 (R255, G000, B175, W000)
175-181	Color 25 (R255, G000, B100, W000)
182-188	Color 26 (R255, G000, B100, W050)
189-195	Color 27 (R255, G000, B025, W050)
196-202	Color 28 (R255, G000, B025, W025)
203-209	Color 29 (R255, G000, B025, W000)
210-216	Color 30 (R000, G000, B000, W255)
217-223	Color 31 (R075, G075, B000, W255)
224-230	Color 32 (R000, G000, B100, W255)
231-255	Color 33 (R255, G255, B255, W255)

Note: Color presets (CH11) overrides RGBW (CH15-18).

Channel 12 – Color running (CH8 and CH13 must be set between 001-255 )

0-15	No function
016-023	Jump 1
024-031	Jump2(pixel effect)
032-039	Jump 3
040-047	Jump4(pixel effect)
048-055	Jump 5
056-063	Jump6(pixel effect)
064-071	Jump 7
072-079	Jump8(pixel effect)
080-087	Jump9
088-095	Jump10(pixel effect)
096-103	Jump11
104-111	Jump12(pixel effect)
112-119	Jump13
120-127	Jump14(pixel effect)
128-135	Jump15
136-143	Jump16(pixel effect)
144-151	Fade 1
152-159	Fade 2
160-167	Fade 3
168-175	Fade 4
176-183	Fade 5
184-191	Fade 6
192-199	Fade 7
200-207	Rainbow 1 (pixel effect)
208-215	Rainbow 2(pixel effect)
216-223	Blue Red fade(pixel effect)
224-231	Blue Green fade(pixel effect)
232-255	Yellow Red fade(pixel effect)

Note: Color running (CH12) overrules color presets (CH11) and RGBW (CH15-18).

Channel 13 – Speed color running

0-255	Gradual speed adjustment, from slow to fast
-------	---

Channel 14 – Functions (CH8 must be set between 001-255 )

0-5	No function
6-10	Show 1
11-20	Show 2
21-30	Show 3
31-40	Show 4
41-50	Show 5
51-60	Show 6
61-70	Show 7
71-80	Show 8
81-90	Slave 1
91-96	Slave 2
97-160	Sound sensitivity, from low sensitivity to high sensitivity
161-170	Pan inversion
171-180	Tilt inversion
181-190	Pan normal
191-200	Tilt normal
201-220	Pan/Tilt blackout ON
221-240	Reset after 5 seconds
241-255	No function

Note: The shows (CH14) overrule color presets (CH11), color running (CH12) and RGBW (CH15-18).

Channel 15 – Red Dimmer intensity (CH8 must be set between 001-255 )

0-255 Gradual adjustment Red from 0 – 100%

Channel 16 – Green Dimmer intensity (CH8 must be set between 001-255 )

0-255 Gradual adjustment Green from 0 – 100%

Channel 17 – Blue Dimmer intensity (CH8 must be set between 001-255 )

0-255 Gradual adjustment Blue from 0 – 100%

Channel 18 – White Dimmer intensity (CH8 must be set between 001-255 )

0-255 Gradual adjustment White from 0 – 100%

66 Channels**Channel 1 – Horizontal movement (Pan)**

Push the slider up, in order to move head horizontally (PAN).

Gradual head adjustment, between 0-255. The head can be turned by 540° and stopped at any position you wish.

Channel 2 – Pan fine 16 bit**Channel 3 – Vertical movement (Tilt)**

Push the slider, up in order to move head vertically (TILT).

Gradual head adjustment, between 0-255. The head can be turned by 360° and stopped at any position you wish.

Channel 4 – Tilt fine 16 bit**Channel 5 – Pan/Tilt speed**

0-255 From maximum speed (0) to minimum speed (255)

Channel 6 – Continuous pan

0-15 No function

16-135 Clockwise rotation, from slow to fast

136-255 Counterclockwise rotation, from slow to fast

Channel 7 – Continuous tilt

0-15 No function

16-135 Clockwise rotation, from slow to fast

136-255 Counterclockwise rotation, from slow to fast

Channel 8 – Master Dimmer intensity

0-255 From dark to brightest 0-100%

Channel 9 – Linear Strobe**(CH8 and CH15, CH16, CH17, CH18 or CH19- CH66 must be set between 001-255 and CH11 between 8-255 )**

0-10 Off

11-255 Linear strobe intensity, from low to high frequency

Channel 10 – Random Strobe**(CH8 and CH15, CH16, CH17, CH18 or CH19- CH66 must be set between 001-255 and CH11 between 8-255 )**

0-10 Off

11-255 Random strobe intensity, from low to high frequency

Channel 11 – Color presets (CH8 must be set between 001-255 )

0-7	No function
8-13	Color 1 (R255, G000, B000, W000)
14-20	Color 2 (R255, G000, B000, W100)
21-27	Color 3 (R255, G000, B000, W200)
28-34	Color 4 (R255, G050, B000, W000)
35-41	Color 5 (R255, G150, B000, W000)
42-48	Color 6 (R255, G255, B000, W000)
49-55	Color 7 (R255, G255, B000, W075)
56-62	Color 8 (R000, G255, B000, W255)
63-69	Color 9 (R000, G255, B000, W150)
70-76	Color 10 (R000, G255, B000, W050)
77-83	Color 11 (R000, G255, B000, W000)
84-90	Color 12 (R000, G255, B050, W000)
91-97	Color 13 (R000, G255, B150, W000)
98-104	Color 14 (R000, G255, B255, W000)
105-111	Color 15 (R000, G255, B255, W075)
112-118	Color 16 (R000, G255, B255, W150)
119-125	Color 17 (R000, G100, B255, W255)
126-132	Color 18 (R000, G000, B255, W100)
133-139	Color 19 (R000, G000, B255, W050)
140-146	Color 20 (R000, G000, B255, W000)
147-153	Color 21 (R075, G000, B255, W000)
154-160	Color 22 (R160, G000, B255, W000)
161-167	Color 23 (R255, G000, B255, W000)
168-174	Color 24 (R255, G000, B175, W000)
175-181	Color 25 (R255, G000, B100, W000)
182-188	Color 26 (R255, G000, B100, W050)
189-195	Color 27 (R255, G000, B025, W050)
196-202	Color 28 (R255, G000, B025, W025)
203-209	Color 29 (R255, G000, B025, W000)
210-216	Color 30 (R000, G000, B000, W255)
217-223	Color 31 (R075, G075, B000, W255)
224-230	Color 32 (R000, G000, B100, W255)
231-255	Color 33 (R255, G255, B255, W255)

Note: Color presets (CH11) overrides RGBW (CH15-CH66).

Channel 12 – Color running (CH8 and CH13 must be set between 001-255 )

0-15	No function
016-023	Jump 1
024-031	Jump2(pixel effect)
032-039	Jump 3
040-047	Jump4(pixel effect)
048-055	Jump 5
056-063	Jump6(pixel effect)
064-071	Jump 7
072-079	Jump8(pixel effect)
080-087	Jump9
088-095	Jump10(pixel effect)
096-103	Jump11
104-111	Jump12(pixel effect)
112-119	Jump13
120-127	Jump14(pixel effect)
128-135	Jump15
136-143	Jump16(pixel effect)

144-151	Fade 1
152-159	Fade 2
160-167	Fade 3
168-175	Fade 4
176-183	Fade 5
184-191	Fade 6
192-199	Fade 7
200-207	Rainbow 1(pixel effect)
208-215	Rainbow 2(pixel effect)
216-223	Blue Red fade(pixel effect)
224-231	Blue Green fade(pixel effect)
232-255	Yellow Red fade(pixel effect)

Note: Color running (CH12) overrules color presets (CH11) and RGBW (CH15-66).

Channel 13 – Speed color running

0-255	Gradual speed adjustment, from slow to fast
-------	---

Channel 14 – Functions (CH8 must be set between 001-255)

0-5	No function
6-10	Show 1
11-20	Show 2
21-30	Show 3
31-40	Show 4
41-50	Show 5
51-60	Show 6
61-70	Show 7
71-80	Show 8
81-90	Slave 1
91-96	Slave 2
97-160	Sound sensitivity, from low sensitivity to high sensitivity
161-170	Pan inversion
171-180	Tilt inversion
181-190	Pan normal
191-200	Tilt normal
201-220	Pan/Tilt blackout ON
221-240	Reset after 5 seconds
241-255	No function

Note: The shows (CH14) overrule color presets (CH11), color running (CH12) and RGBW (CH15-66).

Channel 15 – Red Dimmer intensity all lenses (CH8 must be set between 001-255)

0-255	Gradual adjustment Red from 0 – 100%
-------	--------------------------------------

Channel 16 – Green Dimmer intensity all lenses (CH8 must be set between 001-255)

0-255	Gradual adjustment Green from 0 – 100%
-------	--

Channel 17 – Blue Dimmer intensity all lenses (CH8 must be set between 001-255)

0-255	Gradual adjustment Blue from 0 – 100%
-------	---------------------------------------

Channel 18 – White Dimmer intensity all lenses (CH8 must be set between 001-255)

0-255	Gradual adjustment White from 0 – 100%
-------	--

LED Mapping lenses

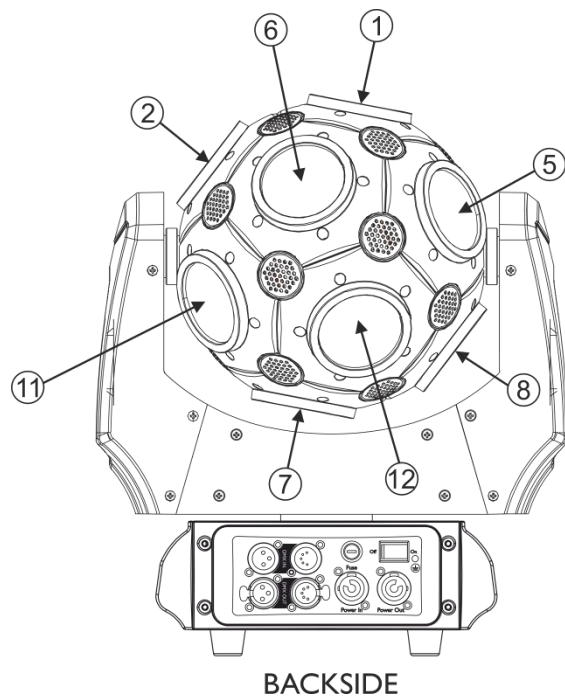
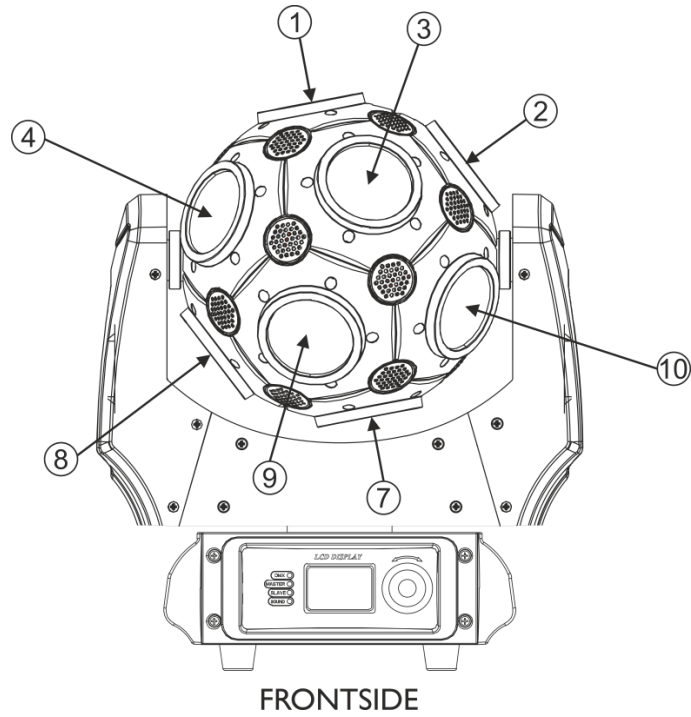

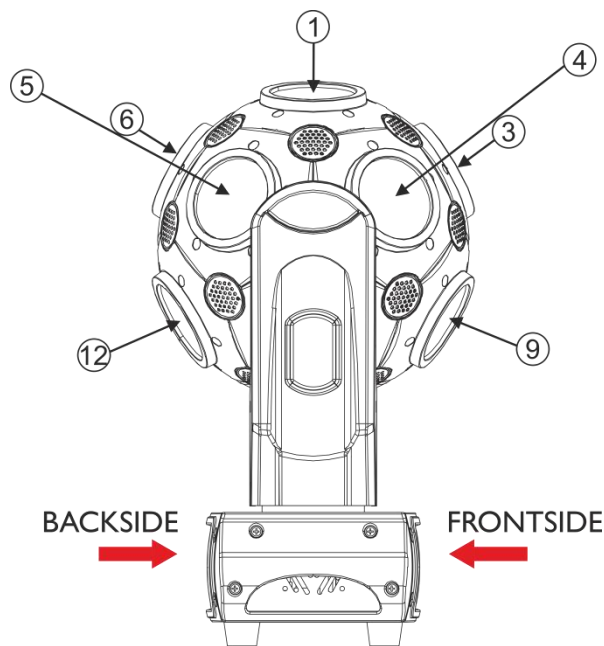

Channel 19 – Lens 1 Red Dimmer intensity (CH8 must be set between 001-255 ⚠)

0-255 Gradual adjustment Red from 0 – 100%

Channel 20 – Lens 1 Green Dimmer intensity (CH8 must be set between 001-255 ⚠)

0-255 Gradual adjustment Green from 0 – 100%

Channel 21 – Lens 1 Blue Dimmer intensity (CH8 must be set between 001-255 ⚠)

0-255 Gradual adjustment Blue from 0 – 100%

Channel 22 – Lens 1 White Dimmer intensity (CH8 must be set between 001-255 ⚠)

0-255 Gradual adjustment White from 0 – 100%

Channel 23 – Lens 2 Red Dimmer intensity (CH8 must be set between 001-255 ⚠)

0-255 Gradual adjustment Red from 0 – 100%

Channel 24 – Lens 2 Green Dimmer intensity (CH8 must be set between 001-255 ⚠)

0-255 Gradual adjustment Green from 0 – 100%

Channel 25 – Lens 2 Blue Dimmer intensity (CH8 must be set between 001-255 ⚠)

0-255 Gradual adjustment Blue from 0 – 100%

Channel 26 – Lens 2 White Dimmer intensity (CH8 must be set between 001-255 ⚠)

0-255 Gradual adjustment White from 0 – 100%

Channel 27 – Lens 3 Red Dimmer intensity (CH8 must be set between 001-255 ⚠)

0-255 Gradual adjustment Red from 0 – 100%

Channel 28 – Lens 3 Green Dimmer intensity (CH8 must be set between 001-255 ⚠)

0-255 Gradual adjustment Green from 0 – 100%

Channel 29 – Lens 3 Blue Dimmer intensity (CH8 must be set between 001-255 ⚠)

0-255 Gradual adjustment Blue from 0 – 100%

Channel 30 – Lens 3 White Dimmer intensity (CH8 must be set between 001-255 )

0-255 Gradual adjustment White from 0 – 100%

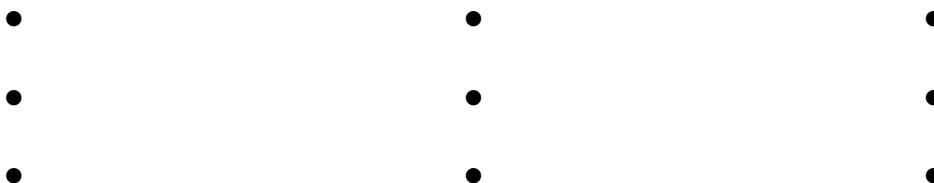

Channel 63 – Lens 12 Red Dimmer intensity (CH8 must be set between 001-255 )

0-255 Gradual adjustment Red from 0 – 100%

Channel 64– Lens 12 Green Dimmer intensity (CH8 must be set between 001-255 )

0-255 Gradual adjustment Green from 0 – 100%

Channel 65 – Lens 12 Blue Dimmer intensity (CH8 must be set between 001-255 )

0-255 Gradual adjustment Blue from 0 – 100%

Channel 66 – Lens 12 White Dimmer intensity (CH8 must be set between 001-255 )

0-255 Gradual adjustment White from 0 – 100%

Maintenance

The operator has to make sure that safety-related and machine-technical installations are to be inspected by an expert after every year in the course of an acceptance test.

The operator has to make sure that safety-related and machine-technical installations are to be inspected by a skilled person once a year.

The following points have to be considered during the inspection:

- 01) All screws used for installing the device or parts of the device have to be tightly connected and must not be corroded.
- 02) There may not be any deformations on housings, fixations and installation spots.
- 03) Mechanically moving parts like axles, eyes and others may not show any traces of wearing.
- 04) The electric power supply cables must not show any damages or material fatigue.

The Showtec Galaxy 360 requires almost no maintenance. However, you should keep the unit clean. Otherwise, the fixture's light-output will be significantly reduced. Disconnect the mains power supply and then wipe the cover with a damp cloth. Wipe the front glass panel clean with glass cleaner and a soft cloth. Do not use alcohol or solvents. The front glass panel will require weekly cleaning, as smoke-fluid tends to build up residues, reducing the light output very quickly. Do not immerse in liquid.

The cooling fans and the internal lenses should be cleaned monthly with a soft brush.

Please clean internal components once a year with a light brush and vacuum cleaner.

Keep connections clean. Disconnect electric power, and then wipe the DMX and audio connections with a damp cloth. Make sure connections are thoroughly dry before linking equipment or supplying electric power.

Replacing a Fuse

Power surges, short-circuit or inappropriate electrical power supply may cause a fuse to burn out. If the fuse burns out, the product will not function whatsoever. If this happens, follow the directions below to do so.

- 01) Unplug the unit from electric power source.
- 02) Insert a flat-headed screwdriver into a slot in the fuse cover. Turn the screwdriver to the left, at the same time gently push a bit (Turn and Push). The fuse will come out.
- 03) Remove the used fuse. If brown or unclear, it is burned out.
- 04) Insert the replacement fuse into the holder where the old fuse was. Reinsert the fuse holder. Be sure to use a fuse of the same type and specification. See the product specification label for details.

Troubleshooting

No Light

This troubleshooting guide is meant to help solve simple problems.

If a problem occurs, carry out the steps below in sequence until a solution is found. Once the unit operates properly, do not carry out following steps.

If the light effect does not operate properly, refer servicing to a technician.

Suspect three potential problem areas as: the power supply, the LEDs, the fuse.

- 01) Power supply. Check if the unit is plugged into an appropriate power supply.
- 02) The LEDs. Return the Galaxy 360 to your Showtec dealer.
- 03) The fuse. See page 30 for replacing the fuse.
- 04) If all of the above appears to be O.K., plug the unit in again.
- 05) If you are unable to determine the cause of the problem, do not open the Galaxy 360, as this may damage the unit and the warranty will become void.
- 06) Return the device to your Showtec dealer.

No Response to DMX

Suspect the DMX cable or connectors, a controller malfunction, a light effect DMX card malfunction.

- 01) Check the DMX setting. Make sure that DMX addresses are correct.
- 02) Check the DMX cable: Unplug the unit; change the DMX cable; then reconnect to electrical power. Try your DMX control again.
- 03) Determine whether the controller or light effect is at fault. Does the controller operate properly with other DMX products? If not, take the controller in for repair. If so, take the DMX cable and the light effect to a qualified technician.

Problem	Probable cause(s)	Solution
One or more fixtures do not function at all	No power to the fixture	<ul style="list-style-type: none"> Check if power is switched on and cables are plugged in
	Primary fuse blown	<ul style="list-style-type: none"> Replace fuse
Fixtures reset correctly, but all respond erratically or not at all to the controller	The controller is not connected.	<ul style="list-style-type: none"> Connect controller.
	3-pin/5-pin XLR Out of the controller does not match XLR Out of the first fixture on the link (i.e. signal is reversed)	<ul style="list-style-type: none"> Install a phase reversing cable between the controller and the first fixture on the link
Fixtures reset correctly, but some respond erratically or not at all to the controller	Poor data quality	<ul style="list-style-type: none"> Check data quality. If much lower than 100 percent, the problem may be a bad data link connection, poor quality or broken cables, missing termination plug, or a defective fixture disturbing the link
	Bad data link connection	<ul style="list-style-type: none"> Inspect connections and cables. Correct poor connections. Repair or replace damaged cables
	Data link not terminated with 120 Ohm termination plug	<ul style="list-style-type: none"> Insert termination plug in output jack of the last fixture on the link
	Incorrect addressing of the fixtures	<ul style="list-style-type: none"> Check address setting
	One of the fixtures is defective and disturbs data transmission on the link	<ul style="list-style-type: none"> Bypass one fixture at a time until normal operation is restored: unplug both connectors and connect them directly together. Have the defective fixture serviced by a qualified technician
	3-pin/5-pin XLR Out on the fixtures does not match (pins 2 and 3 reversed)	<ul style="list-style-type: none"> Install a phase-reversing cable between the fixtures or swap pin 2 and 3 in the fixture that behaves erratically
No light or LEDs cuts out intermittently	Fixture is too hot	<ul style="list-style-type: none"> Allow the fixture to cool down Clean the fans Make sure that the air vents and the front lens are not blocked Turn up the air conditioning
	LEDs damaged	<ul style="list-style-type: none"> Disconnect the fixture and return it to your dealer
	The power supply settings do not match local AC voltage and frequency	<ul style="list-style-type: none"> Disconnect fixture. Check settings and correct if necessary

Product Specifications

Model:	Showtec Galaxy 360
Input Voltage:	100-240V AC
Power consumption:	190W (full output)
DMX linking:	30pcs
Power linking:	10pcs
Fuse:	3A/250V
Dimensions:	335 x 145 x 395 mm (LxWxH)
Weight:	7,2 kg
Operating and Programming:	
Signal pin OUT:	Pin 1 (earth), pin 2 (-), pin 3 (+)
DMX mode:	10, 18, 66 channels
Signal input:	3-pin/5-pin XLR IN
Signal output:	3-pin/5-pin XLR OUT
Electro-mechanical effects:	
Light source:	12 x 9W RGBW LED
Beam angle:	4°
Pan:	0-540° & continuous
Ball:	0-360° & continuous
Pan/Tilt resolution:	16 bit
Dimmer:	0-100%
Strobe:	0-20Hz
Dimmer curves:	Linear, Square, I-Square, S curve
Control mode:	DMX, Auto, Manual, Sound, Master/Slave
Housing:	Black metal & flame-retardant plastic
DMX-control:	via standard DMX-controller
Onboard:	Display including gravity sensor
Data connections:	3-pin/5-pin XLR IN/OUT
Power connections:	Pro Power IN/OUT
Cooling:	Internal fan
Max. ambient temperature t_a :	40°C
Max. housing temperature t_B :	80°C
Minimum distance:	
Minimum distance from flammable surfaces:	0,5 m
Minimum distance to lighted object:	1 m

Design and product specifications are subject to change without prior notice



Website: www.Showtec.info

Email: service@highlite.nl

Dimensions

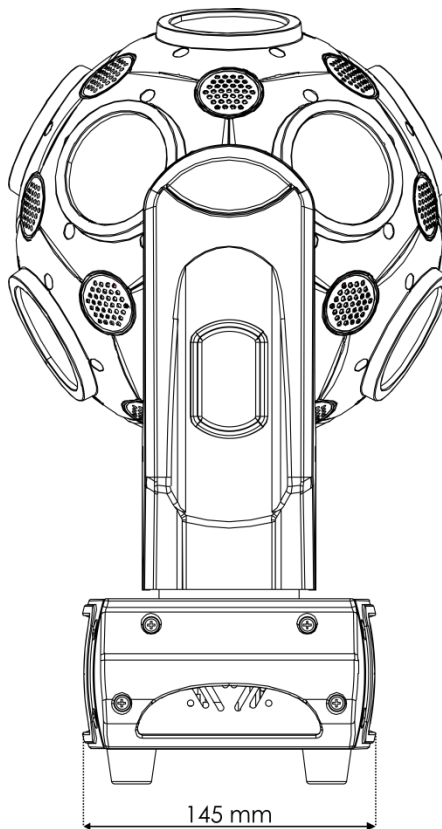
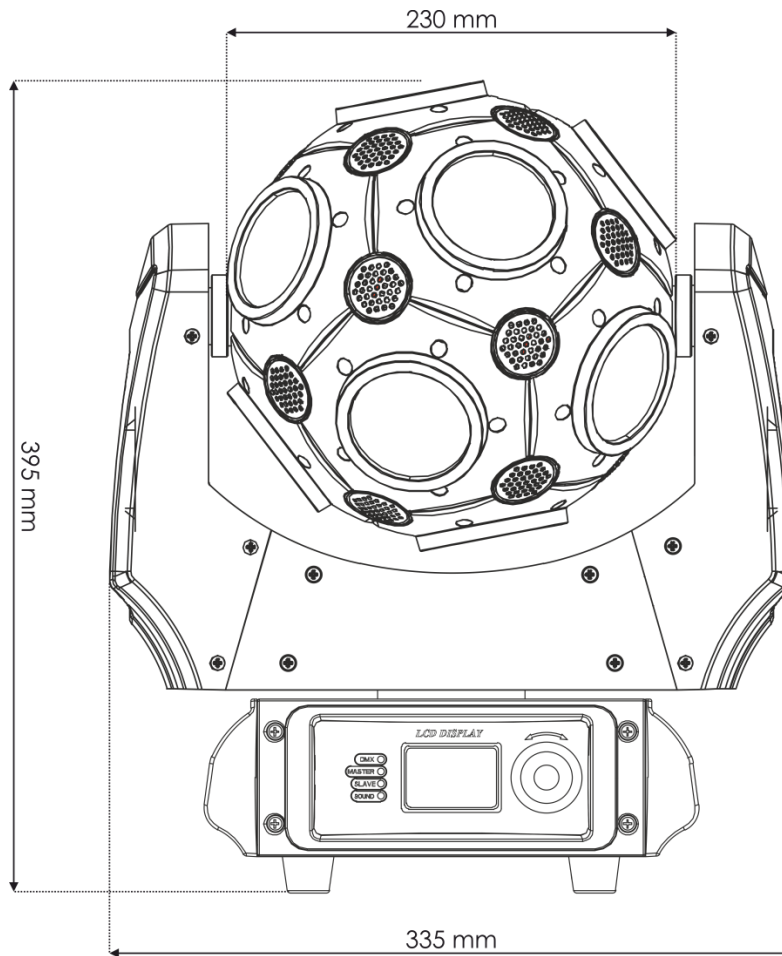



©2016 Showtec