

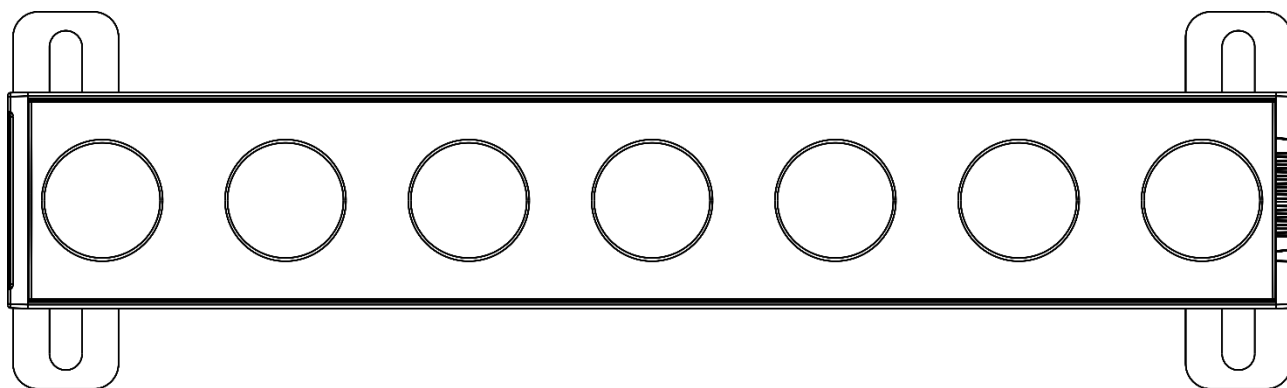

MANUAL



ENGLISH

Candela Pix 50

V2

Ordercode: 41280

Table of contents

Warning	2
Safety Instructions	2
Operating Determinations	4
Rigging	4
Connection with the mains	5
Return Procedure	6
Claims	6
Description of the device	7
Optional accessories	7
Overview	8
Backside	8
Side	8
Installation	9
Set Up and Operation	9
Control Modes	9
One Candela Pix (Auto program, Built-in programs and Manual)	9
Multiple Candela Pixs (Master/Slave control)	9
Multiple Candela Pixs (DMX512 Mode)	10
Fixture Linking	11
Data Cabling	11
Control Panel	12
DMX Control Mode	12
DMX Addressing	12
Menu overview	13
Main Menu Options	14
1. DMX Address/ DMX Configuration	14
2. Manual	15
3. Auto program	15
4. Built-in programs	15
5. Master/slave	16
6. Settings	16
6.1. Curves Select	17
6.2. Pixel Invert	17
6.3. PWM Frequency	18
6.4. DMX Fail	18
6.5. DMX Sync	18
6.6. Lock	19
6.7. Key Backlight	19
6.8. Factory	19
7. Information	19
DMX Channels	20
4 Channels	20
6 Channels	20
9 DMX Channels	21
28 DMX Channels	23
Maintenance	24
Troubleshooting	24
No Light	24
No Response to DMX	24
Product Specifications	26
Dimensions	27
Notes	28

Warning



**For your own safety, please read this user manual carefully
before your initial start-up!**



Unpacking Instructions

Immediately upon receiving this product, carefully unpack the carton and check the contents to ensure that all parts are present, and have been received in good condition. Notify the dealer immediately and retain packing material for inspection if any parts appear to be damaged from shipping or the carton itself shows signs of mishandling. Save the carton and all packing materials. In the event that the fixture must be returned to the factory, it is important that the fixture be returned in the original factory box and packing.

Your shipment includes:

- Showtec Candela Pix 50
- 2 brackets and screws (pre-installed)
- Quick-lock
- PowerCON True 1 powercable 1,5m
- User manual

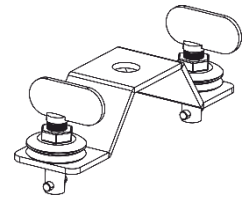
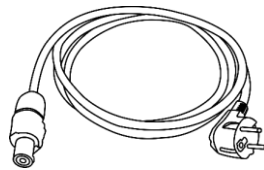
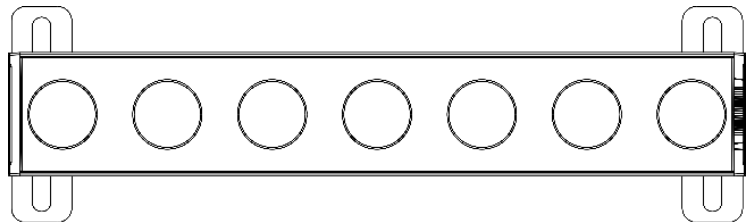

LED Expected Lifespan

LEDs gradually decline in brightness over time. HEAT is the dominant factor that leads to the acceleration of this decline. Packaged in clusters, LEDs exhibit higher operating temperatures than in ideal or singular optimum conditions. For this reason when all color LEDs are used at their fullest intensity, life of the LEDs is significantly reduced. If improving the lifespan is of higher priority, place care in providing for lower operational temperatures. This may include climatic-environmental and the reduction of overall projection intensity.



CAUTION!

**Keep this device away from rain and moisture!
Unplug mains lead before opening the housing!**



Safety Instructions

Every person involved with the installation, operation and maintenance of this device has to:

- be qualified
- follow the instructions of this manual



**CAUTION! Be careful with your operations.
With a dangerous voltage you can suffer
a dangerous electric shock when touching the wires!**



Before your initial start-up, please make sure that there is no damage caused by transportation. Should there be any, consult your dealer and do not use the device.

To maintain perfect condition and to ensure a safe operation, it is absolutely necessary for the user to follow the safety instructions and warning notes written in this manual.

Please consider that damages caused by manual modifications to the device are not subject to warranty. This device contains no user-serviceable parts. Refer servicing to qualified technicians only.

IMPORTANT:

The manufacturer will not accept liability for any resulting damages caused by the non-observance of this manual or any unauthorized modification to the device.

- Never let the power cord come into contact with other cables! Handle the power cord and all connections with the mains with particular caution!
- Never modify, bend, mechanically strain, put pressure on, pull or heat up the power cord.
- Never strain the cable insert or the female part in the device. There must always be sufficient cable going to the device. Otherwise, the cable will be damaged, which can cause serious damage.
- Never remove warning or informative labels from the unit.
- Never use anything to cover the ground contact.
- Never lift the device holding it by the projector-head, as the mechanics may be damaged. Always hold the device by the transport handles.
- Never place any material over the LEDs or lens.
- Never look directly into the light source.
- Never leave any cables lying around.
- Never use the device during thunderstorms, unplug the device immediately.
- Never leave various parts of the packaging (plastic bags, polystyrene foam, nails, etc.) within children's reach, as they are potential sources of danger.
- Do not insert objects into air vents.
- Do not open the device and do not modify the device.
- Do not connect this device to a dimmer pack.
- Do not switch the device on and off in short intervals, as this will reduce the device's life.
- Do not touch the device's housing bare-handed during its operation (housing becomes hot). Allow the device to cool for at least 5 minutes before handling.
- Do not shake the device. Avoid brute force when installing or operating the device.
- Only operate the device after having checked if the housing is firmly closed and all screws are tightly fastened.
- Only operate the device after having familiarized with its functions.
- Avoid flames and do not put close to flammable liquids or gases.
- Always keep the case closed while operating.
- Always allow a free air space of at least 50 cm around the unit for ventilation.
- Always disconnect power from the mains, when device is not used or before cleaning! Only handle the power cord holding it by the plug. Never pull out the plug by tugging the power cord.
- Make sure that the device is not exposed to extreme heat, moisture or dust.
- Make sure that the available voltage is not higher than stated on the rear panel.
- Make sure that the power cord is never crimped or damaged. Check the device and the power cord from time to time.
- Make sure that the core diameter of extension cords and power cords is sufficient for the required power consumption of the device.
- If the lens or LEDs are obviously damaged, it has to be replaced to prevent its functions from being impaired, due to cracks or deep scratches.
- If the external cable is damaged, it has to be replaced by a qualified technician.
- If device was dropped or struck, disconnect mains power supply immediately. Have a qualified engineer inspect for safety before operating.
- If the device has been exposed to drastic temperature fluctuation (e.g. after transportation), do not switch it on immediately. The arising condensation water might damage your device. Leave the device switched off until it has reached room temperature.
- If your Showtec device fails to work properly, discontinue the use immediately. Pack the unit securely (preferably in the original packing material), and return it to your Showtec dealer for service.
- For adult use only. The device must be installed beyond the reach of children. Never leave the unit running unattended.
- Never attempt to bypass the thermostatic switch or fuses.

- For replacement use fuses of same type and rating only.
- The user is responsible for correct positioning and operating of the device. The manufacturer will not accept liability for damages caused by the misuse or incorrect installation of this device.
- This device falls under protection class I. Therefore it is essential to connect the yellow/green conductor to earth.
- Repairs, servicing and electric connection must be carried out by a qualified technician.
- WARRANTY: Till one year after date of purchase.

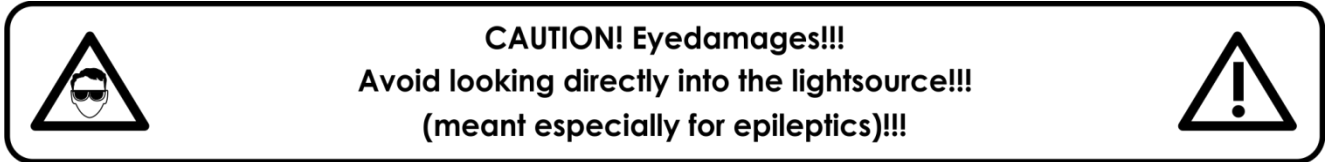

Operating Determinations

- This device is not designed for permanent operation. Consistent operation breaks will ensure that the device will serve you for a long time without defects.
- The minimum distance between light output and the illuminated surface must be bigger than 1 meter.
- In order to eliminate wear and improve the device's lifespan, during periods of non-use, completely disconnect from power source via breaker or by unplugging.
- The maximum ambient temperature $t_a = 40^\circ\text{C}$ must never be exceeded.
- The relative humidity must not exceed 50 % with an ambient temperature of 40°C .
- If this device is operated in any other way than the one described in this manual, the product may suffer damages and the warranty becomes void.
- Any other operation may lead to dangers like short-circuit, burns, electric shock, crash, etc.

You endanger your own safety and the safety of others!

Rigging

Please follow the European and national guidelines concerning rigging, trussing and all other safety issues.

Do not attempt the installation yourself!

Always let the installation be carried out by an authorized dealer!

Procedure:

- If the device is lowered from the ceiling or high joists, professional trussing systems have to be used.
- Use a clamp to mount the device, with the mounting-bracket, to the trussing system.
- The device must never be fixed swinging freely in the room.
- The installation must always be secured with a safety attachment, e.g. an appropriate safety net or safety-cable.
- When rigging, derigging or servicing the device, always make sure, that the area below the installation place is blocked and staying in the area is forbidden.

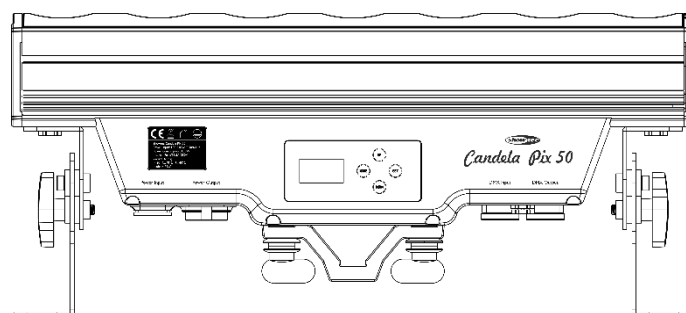

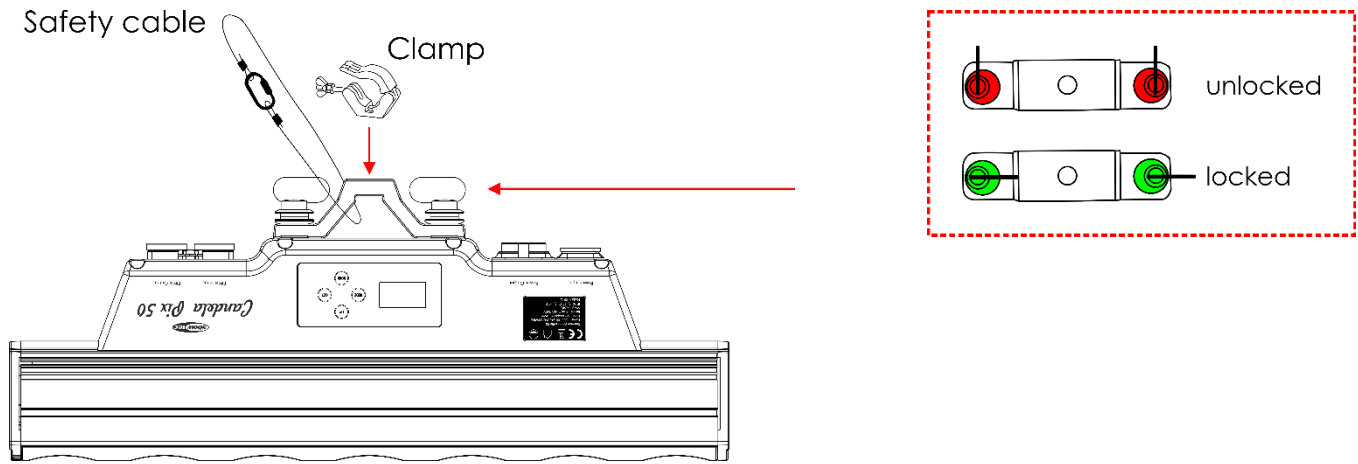

The Candela Pix 50 can be placed on a flat stage floor or mounted to any kind of truss by a clamp. Improper installation can cause serious injuries and/or damage of property!

Connection with the mains

Connect the device to the mains with the power plug. Always check if the right color cable is connected to the right place.

International	EU Cable	UK Cable	US Cable	Pin
L	BROWN	RED	YELLOW/COPPER	PHASE
N	BLUE	BLACK	SILVER	NEUTRAL
	YELLOW/GREEN	GREEN	GREEN	PROTECTIVE GROUND

Make sure that the device is always connected properly to the earth!

Improper installation can cause serious damage and/or damage of property!





Return Procedure



Returned merchandise must be sent prepaid and in the original packing, call tags will not be issued. Package must be clearly labeled with a Return Authorization Number (RMA number). Products returned without an RMA number will be refused. Highlite will not accept the returned goods or any responsibility. Call Highlite 0031-455667723 or mail aftersales@highlite.com and request an RMA prior to shipping the fixture. Be prepared to provide the model number, serial number and a brief description of the cause for the return. Be sure to properly pack fixture, any shipping damage resulting from inadequate packaging is the customer's responsibility. Highlite reserves the right to use its own discretion to repair or replace product(s). As a suggestion, proper UPS packing or double-boxing is always a safe method to use.

Note: If you are given an RMA number, please include the following information on a piece of paper inside the box:

- 01) Your name
- 02) Your address
- 03) Your phone number
- 04) A brief description of the symptoms

Claims

The client has the obligation to check the delivered goods immediately upon delivery for any shortcomings and/or visible defects, or perform this check after our announcement that the goods are at their disposal. Damage incurred in shipping is the responsibility of the shipper; therefore the damage must be reported to the carrier upon receipt of merchandise.

It is the customer's responsibility to notify and submit claims with the shipper in the event that a fixture is damaged due to shipping. Transportation damage has to be reported to us within one day after receipt of the delivery.

Any return shipment has to be made post-paid at all times. Return shipments must be accompanied with a letter defining the reason for return shipment. Non-prepaid return shipments will be refused, unless otherwise agreed in writing.

Complaints against us must be made known in writing or by fax within 10 working days after receipt of the invoice. After this period complaints will not be handled anymore.

Complaints will only then be considered if the client has so far complied with all parts of the agreement, regardless of the agreement of which the obligation is resulting.

Description of the device

Features

The Showtec Candela Pix 50 is an outdoor LED bar with 7 x 4-in-1 RGBW LEDs. It is a LED bar with high output and great effects.

- Powercon TRUE1 in & out
- IP 65 Rating
- Exceptionally smooth RGBW color mixing
- 4-in-1 RGBW LEDs
- Power and data daisy chain
- Pixel control
- OLED display
- Power Supply: 100-240V AC, 50/60Hz
- Power Consumption: 118W@FO
- Drive current: 1000mA
- Refresh rate: 250 Hz, 4 KHz, 8 KHz, 16 KHz
- Light source: 7 x 15W 4-in-1 RGBW LEDs
- Beam angle: 10°
- Lux @2m: Red: 3862
Green: 7355
Blue: 1780
White: 8273
Full Output: 15242
- Max. distance: 10m
- Lens Plate: Tempered Glass
- IP rating: IP-65
- Control Mode: DMX512
- DMX modes: 4, 6, 9 or 28 channels
- Control: Auto Program, Built-in programs, Manual, Master/Slave, DMX
- Dimmer: 0-100%
- Strobe: 0-20Hz
- Connections: Dedicated PowerCON True 1 IP65 (IN/OUT), Dedicated 3 pin XLR IP65 (IN/OUT)
- Housing: black aluminum
- Cooling: Aluminum housing
- Dimensions: 515 x 150 x 240 mm (LxWxH) (incl. brackets)
- Weight: 6,5 kg

Note: Knowledge of DMX is required to fully utilize this unit.

Optional accessories

[41282](#) Diffuser for Candela Pix 50 (20°)

[41283](#) Diffuser for Candela Pix 50 (40°)

[41287](#) Diffuser for Candela Pix 50 (15° x 60°)

Overview

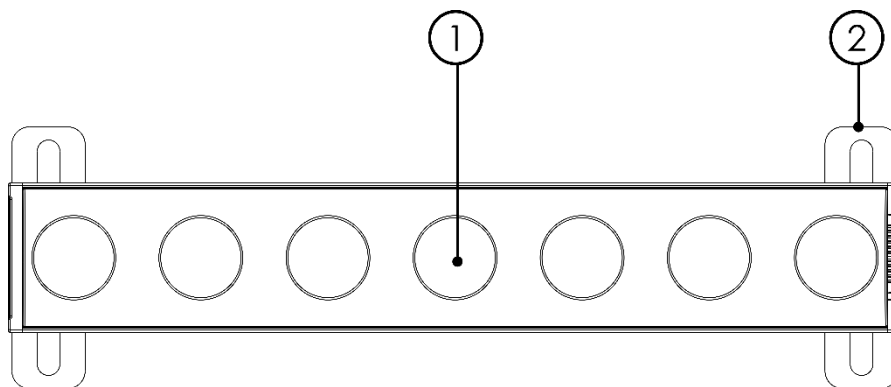

Fig. 01

- 01) 7 x 15W 4-in-1 RGBW LEDs
- 02) Mounting bracket with inclination screw

Backside

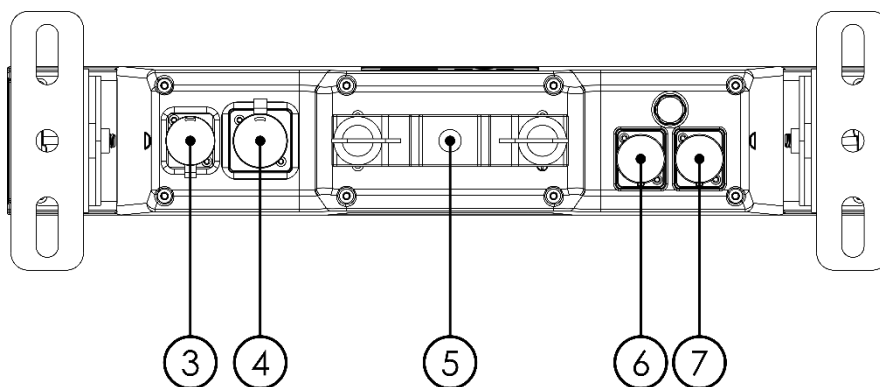

Fig. 02

- 03) Dedicated PowerCON True 1 connector 100-240V IN (IP65)
- 04) Dedicated PowerCON True 1 connector 100-240V OUT (IP65)
- 05) Quick-lock
- 06) Dedicated 3-pin DMX signal connector IN (IP65)
- 07) Dedicated 3-pin DMX signal connector OUT (IP65)

Side

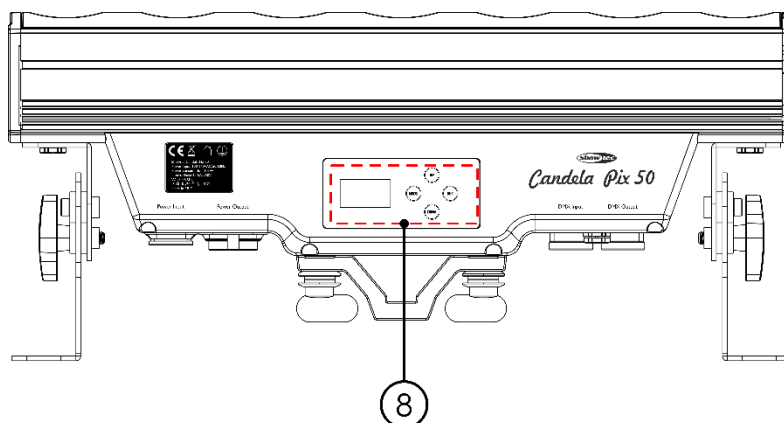

Fig. 03

- 08) OLED display with Menu buttons

Installation

Remove all packing materials from the Candela Pix 50.

Check that all foam and plastic padding is removed. Connect all cables.

Do not supply power before the whole system is set up and connected properly.

Always disconnect from electric mains power supply before cleaning or servicing.

Damages caused by non-observance are not subject to warranty.

Set Up and Operation

Follow the directions below, as they pertain to your preferred operation mode.

Before plugging the unit in, always make sure that the power supply matches the product specification voltage. Do not attempt to operate a 120V specification product on 230V power, or vice versa.

Connect the device to the main power supply.

Control Modes

There are 5 modes:

- Auto program
- Built-in programs
- Manual
- Master/Slave
- DMX512 (CH4, CH6, CH9, CH28)

One Candela Pix (Auto program, Built-in programs and Manual)

- 01) Fasten the effect light onto firm trussing. Leave at least 0,5 meter on all sides for air circulation.
- 02) Always use a safety cable (ordercode 70140 / 70141).
- 03) Plug the end of the electric mains power cord into a proper electric power supply socket.
- 04) When the Candela Pix 50 is not connected with a DMX cable, it functions as a stand-alone device. Please see pages 16-17 for more information about the Auto program mode, Built-in programs or Manual.

Multiple Candela Pixs (Master/Slave control)

- 01) Fasten the effect light onto firm trussing. Leave at least 0,5 meter on all sides for air circulation.
- 02) Always use a safety cable (ordercode 70140 / 70141).
- 03) Plug the end of the electric mains power cord into a proper electric power supply socket.
- 04) Use a 3-p XLR cable to connect the Candela Pixs and other devices.

The pins:



1. Earth
2. Signal (-)
3. Signal (+)

- 05) Link the units as shown in Fig. 04, connect a DMX signal cable from the first unit's DMX "out" socket to the second unit's "in" socket. Repeat this process to link the second and third units. You can use the same functions on the master device as described on pages 16-17 (Auto program, Built-in programs or Manual). This means you can set your desired operation mode on the master device and all slave devices will react the same as the master device.

Multiple Candela Pixs (Master/Slave control)

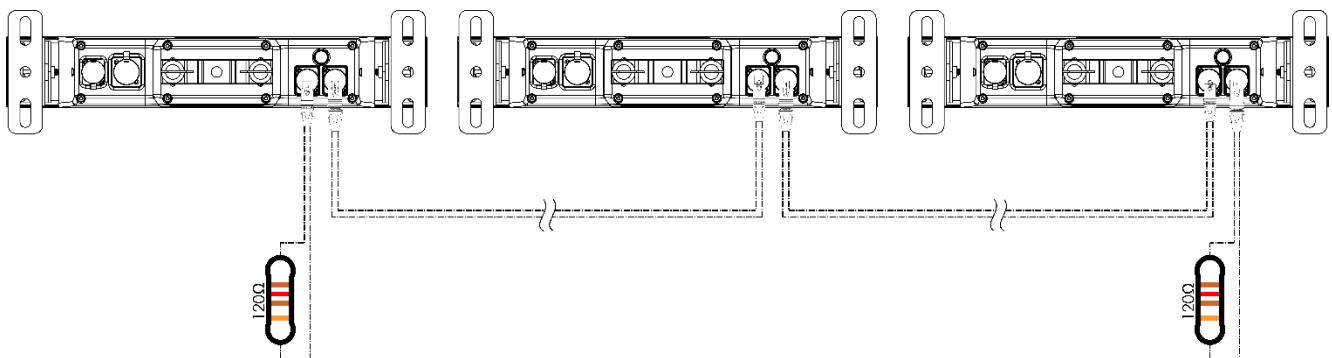
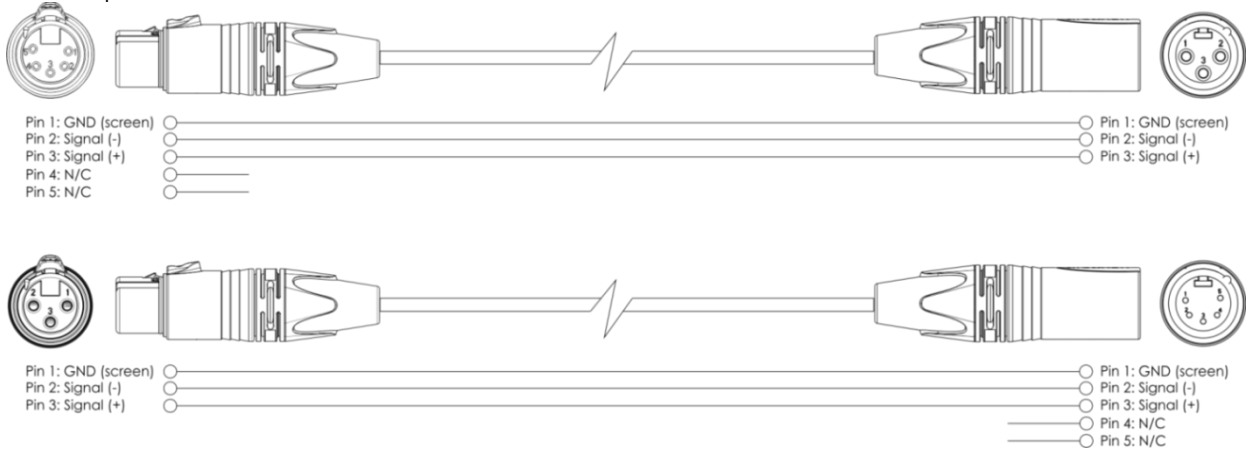

Fig. 04

Multiple Candela Pixs (DMX512 Mode)

- 01) Fasten the effect light onto firm trussing. Leave at least 0,5 meter on all sides for air circulation.
- 02) Always use a safety cable (ordercode 70140 / 70141).
- 03) Use a 3-p XLR cable to connect the Candela Pixs and other devices.



- 04) Link the units as shown in Fig. 05, Connect a DMX signal cable from the first unit's DMX "out" socket to the second unit's "in" socket. Repeat this process to link the second and third units.
- 05) Supply electric power: Plug electric mains power cords into each unit's PowerCON True 1 socket, then plug the other end of the mains power cord into proper electric power supply sockets, starting with the first unit. Do not supply power before the whole system is set up and connected properly.

Multiple Candela Pixs DMX Set Up

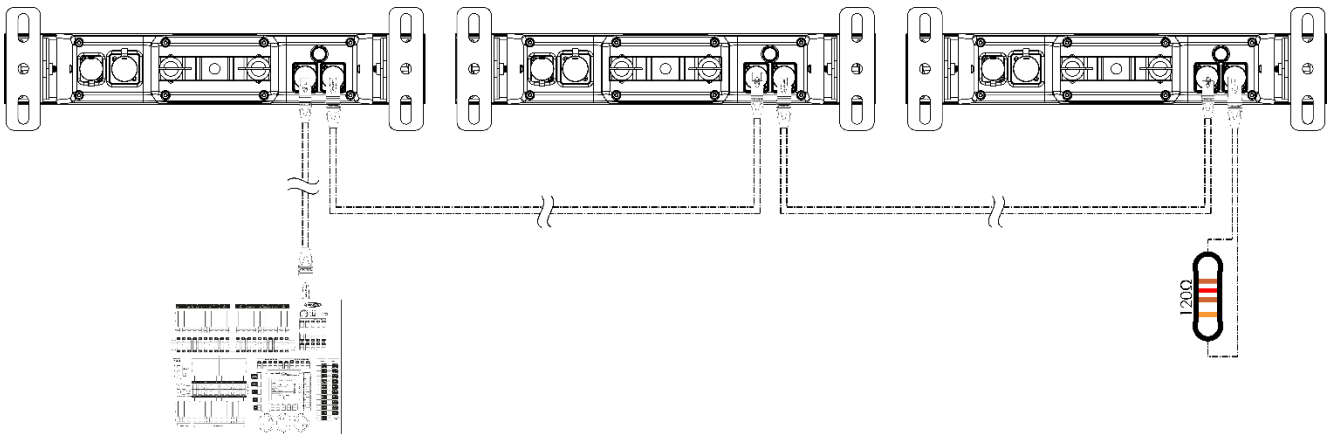

Fig. 05

Note: Link all cables before connecting electric power!

Fixture Linking

You will need a serial data link to run light shows of one or more fixtures using a DMX-512 controller or to run synchronized shows on two or more fixtures set to a master/slave operating mode. The combined number of channels required by all the fixtures on a serial data link determines the number of fixtures the data link can support.

Important: Fixtures on a serial data link must be daisy-chained in a single line. To comply with the EIA-485 standard, no more than 30 devices should be connected on one data link. Connecting more than 30 fixtures on one serial data link without the use of a DMX optically isolated splitter may result in deterioration of the digital DMX signal.

Maximum recommended DMX data link distance: 100 meters
 Maximum recommended number on a DMX data link: 30 fixtures
 Maximum recommended number of fixtures on a power link: 7 @ 100V
 Maximum recommended number of fixtures on a power link: 16 @ 240V



Data Cabling

To link fixtures together you must obtain data cables. You can purchase DAP Audio certified DMX cables directly from a dealer/distributor or construct your own cable. If you choose to create your own cable please use data-grade cables that can carry a high quality signal and are less prone to electromagnetic interference.

DAP Audio DMX Data Cables

- DAP Audio Basic microphone cable for allround use. bal. XLR/M 3-pin > XLR/F 3-pin. **Ordercode** FL01150 (1,5 m), FL013 (3 m), FL016 (6 m), FL0110 (10 m), FL0115 (15 m), FL0120 (20 m).
- DAP Audio X-type data cable XLR/M 3-pin > XLR/F 3-pin. **Ordercode** FLX0175 (0,75 m), FLX01150 (1,5 m), FLX013 (3 m), FLX016 (6 m), FLX0110 (10 m).
- DAP Audio cable for the demanding user with exceptional audio-qualities and connector made by Neutrik®. **Ordercode** FL71150 (1,5 m), FL713 (3 m), FL716 (6 m), FL7110 (10 m).
- DAP Audio cable for the demanding user with exceptional audio-qualities and connector made by Neutrik®. **Ordercode** FL7275 (0,75 m), FL72150 (1,5 m), FL723 (3 m), FL726 (6 m), FL7210 (10 m).
- DAP Audio 110 Ohm cable with digital signal transmission. **Ordercode** FL0975 (0,75 m), FL09150 (1,5 m), FL093 (3 m), FL096 (6 m), FL0910 (10 m), FL0915 (15 m), FL0920 (20 m).
- DAP Audio data cable FL08 DMX/AES-EBU, XLR/M 5-pin > XLR/F 5-pin. **Ordercode** FL08150 (1,5 m), FL083 (3 m), FL086 (6 m), FL0810 (10 m), FL0820 (20 m).
- DAP Audio DMX adapter: 5-pin > 3-pin. **Ordercode** FLA29.
- DAP Audio DMX adapter: 3-pin > 5-pin. **Ordercode** FLA30.
- DAP Audio DMX Terminator 3-pin. **Ordercode** FLA42.
- DAP Audio DMX Terminator 5-pin. **Ordercode** FLA43.

The Candela Pix 50 can be operated with a controller in **control mode** or without the controller in **stand-alone mode**.

Control Panel

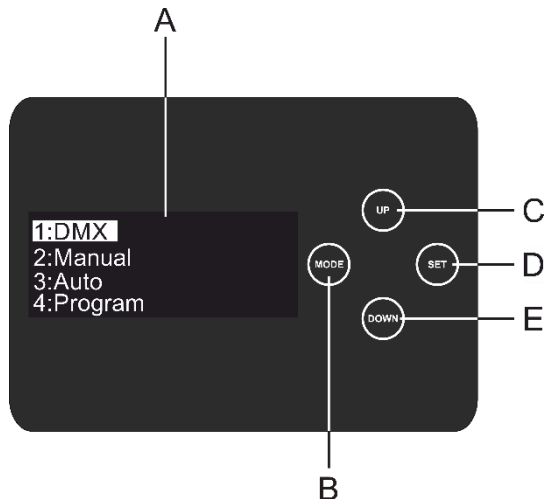

- A. OLED Display
- B. MODE button
- C. UP Button
- D. SET Button
- E. DOWN Button

Fig. 06

DMX Control Mode

The fixtures are individually addressed on a data-link and connected to the controller. The fixtures respond to the DMX signal from the controller. (When you select the DMX address and save it, the controller will display the saved DMX address the next time.)

DMX Addressing

The control panel on the backside of the device allows you to assign the DMX fixture address, which is the first channel from which the Candela Pix will respond to the controller. Please note when you use the controller, the unit has up to **28** channels. When using multiple Candela Pixs, make sure you set the DMX addresses right. Therefore, the DMX address of the first Candela Pix should be **1(001)**; the DMX address of the second Candela Pix should be **1+28=29 (029)**; the DMX address of the third Candela Pix should be **29+28=57 (057)**, etc. Please, be sure that you do not have any overlapping channels in order to control each Candela Pix correctly. If two or more Candela Pixs are addressed similarly, they will work similarly.

Controlling:

After having addressed all Candela Pixs, you may now start operating these via your lighting controller.

Note: After switching on, the Candela Pix will automatically detect whether DMX 512 data is received or not. If there is no data received at the DMX-input, the text "**DMX In**" on the control panel will not appear. If not, the problem may be:

- The XLR cable from the controller is not connected with the input of the Candela Pix.
- The controller is switched off or defective, the cable or connector is defective, or the signal wires are swapped in the input connector.

Note: It is necessary to insert a XLR termination plug (with 120 Ohm) in the last fixture in order to ensure proper transmission on the DMX data link.



Display Off after 25 seconds



When no button is pressed for 30 seconds, the display will turn off. To light up the display, you have to press the **MODE** and **SET** button. When the timer on the display reaches zero, release the buttons and the display will light up.

Menu overview

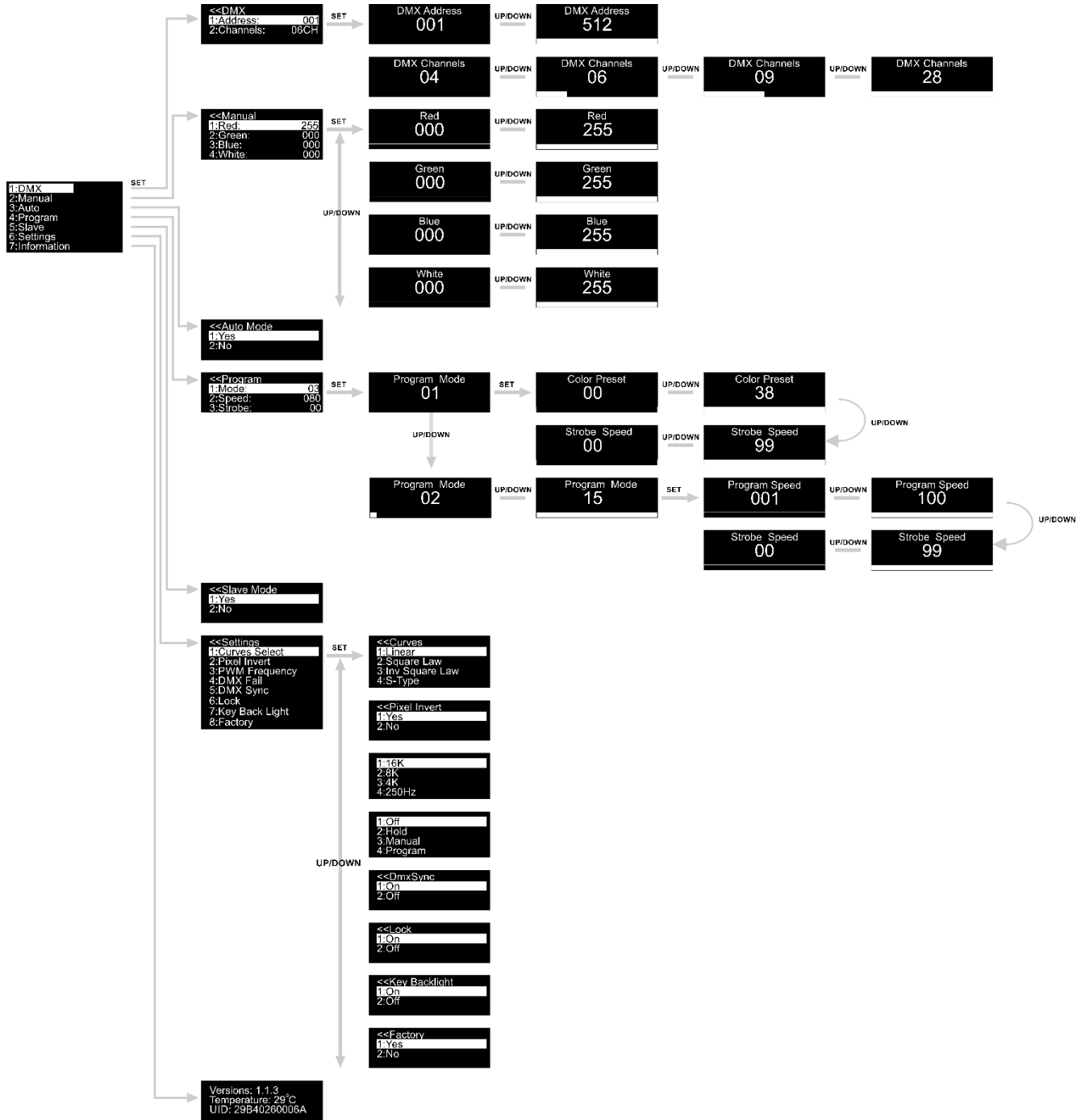

The Candela Pix 50 will show the current software version and actual temperature at start-up !

```

    Versions: 1.1.3
    Temperature: 29°C
    UID: 29B40260006A
    
```

Main Menu Options

- 01) Press the **MODE** or **SET** button to open the main menu.
- 02) Press the **UP/DOWN** buttons to scroll through the menu. The display will show:

```

1:DMX
2:Manual
3:Auto
4:Program
5:Slave
6:Settings
7:Information
  
```

- 03) Press the **SET** button to open the desired menu.
- 04) Press the **MODE** button to return to the previous menu.

1. DMX Address/ DMX Configuration

In this menu you can set the DMX address and DMX configuration.

- 01) While in the main menu, press the **UP/DOWN** buttons until the display shows **DMX**.
- 02) Press the **SET** button to open the menu, the display will show:

```

<<DMX
1:Address: 001
2:Channels: 06CH
  
```

- 03) With the **UP/DOWN** buttons you can set the DMX address or the desired DMX configuration.
- 04) If you choose the desired DMX address 001, press the **SET** button to open the submenu.
- 05) Press the **UP/DOWN** buttons to set the desired address. The adjustment range is between 000-512.
- 06) If you choose the desired DMX configuration DMX Channels
04, press the **SET** button to open the submenu.
- 07) Press the **UP/DOWN** buttons to choose one of the 4 options:

DMX Channels 04	4 Channel
DMX Channels 06	6 Channels
DMX Channels 09	9 Channels
DMX Channels 28	28 Channels

- 08) Press the **SET** button to confirm your choice.

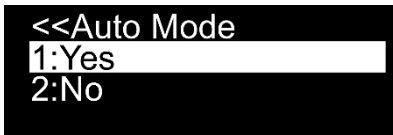

2. Manual

In this menu you can individually set the static colors.

- 01) While in main menu, press the **UP/DOWN** buttons until the display shows **Manual**.
- 02) Press the **SET** button to open the menu, the display will show:

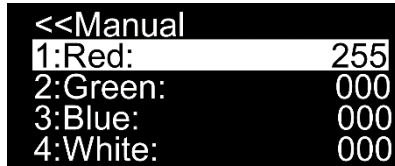

- 03) Press the **UP/DOWN** buttons to scroll between the static colors Red, Green, Blue and White.
- 04) If you choose the desired color, press the **SET** button to adjust the color intensity.
- 05) Press the **UP/DOWN** buttons to set the intensity from the desired colors, the adjustment ranges are between:



3. Auto program

In this menu you can activate the Auto program.

- 01) While in main menu, press the **UP/DOWN** buttons until the display shows **Auto**.
- 02) Press the **SET** button to open the menu, the display will show:

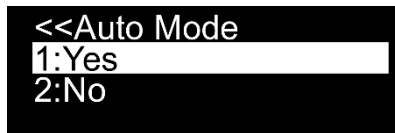

- 03) Press the **UP/DOWN** buttons to choose between **Yes** or **No**.
- 04) If you choose **Yes**, the Candela Pix will immediately start the Auto program.
- 05) If you choose **No**, the Candela Pix doesn't start the Auto program and the output will blackout.
- 06) Press the **SET** button to confirm your choice.

4. Built-in programs

In this menu you can set the built-in programs.

- 01) While in main menu, press the **UP/DOWN** buttons until the display shows **Program**.
- 02) Press the **SET** button to open the menu, the display will show:

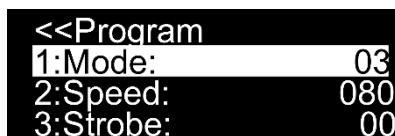

- 03) Press the **SET** button to open the submenu and use the **UP/DOWN** buttons to choose between the built-in programs. The adjustment range is between 01-15.
- 04) If you choose **Program Mode 01**, press the **UP/DOWN** buttons to choose the desired color or set the strobe frequency.

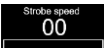
- 05) If you choose the , press the **SET** button to open the submenu.
- 06) Press the **UP/DOWN** buttons to choose one of the 38 available preset colors 00-38.
- 07) If you choose the strobe frequency , press the **SET** button to open the submenu.
- 08) Press the **UP/DOWN** buttons to set the desired strobe frequency. The adjustment range is between 00-99, from OFF to high strobe frequency.
- 09) If you choose **Program Mode 02-15**, press the **UP/DOWN** buttons to set the program speed and strobe frequency.
- 10) If you choose the program speed 001, press the **SET** button to open the submenu.
- 11) Press the **UP/DOWN** buttons to set the desired program speed. The adjustment range is between 001-100, from slow to fast.
- 12) If you choose the strobe frequency 00, press the **SET** button to open the submenu.
- 13) Press the **UP/DOWN** buttons to set the desired strobe frequency. The adjustment range is between 00-99, from OFF to high strobe frequency.

5. Master/slave

In this menu you can set the device as a slave.

- 01) While in main menu, press the **UP/DOWN** buttons until the display shows **Slave**.
- 02) Press the **SET** button to open the menu, the display will show:

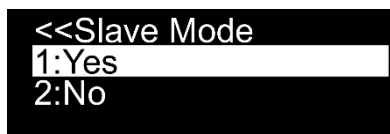

- 03) If you choose **Yes**, the device will become a slave device.
- 04) If the device has been set to slave, it will react the same as its master device.
- 05) If you choose **No**, it is automatically classified as a master device.
- 06) Press the **SET** button to confirm your choice.

6. Settings

In this menu you can set several settings of the device.

- 01) While in main menu, press the **UP/DOWN** buttons until the display shows **Settings**.
- 02) Press the **SET** button to open the menu, the display will show:

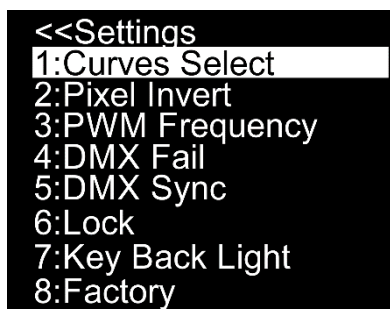

- 03) Press the **UP/DOWN** buttons to scroll between the following menus: Curves Select, Pixel Invert, PWM Frequency, DMX Fail, DMX Sync, Lock, Key Back Light and Factory.

6.1. Curves Select

In this menu you can adjust the dimming of the device by choosing a dimming curve.

- 01) Press the **UP/DOWN** buttons until the display shows **Curves Select**.
- 02) Press the **SET** button to open the menu, the display will show:

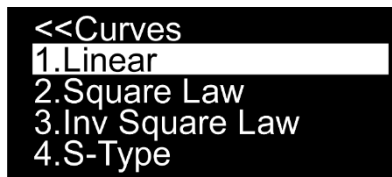

- 03) Press the **UP/DOWN** buttons to choose the desired dimming curve out of the 4 available options:

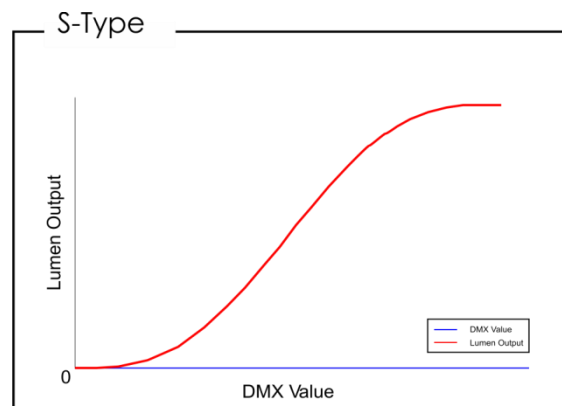
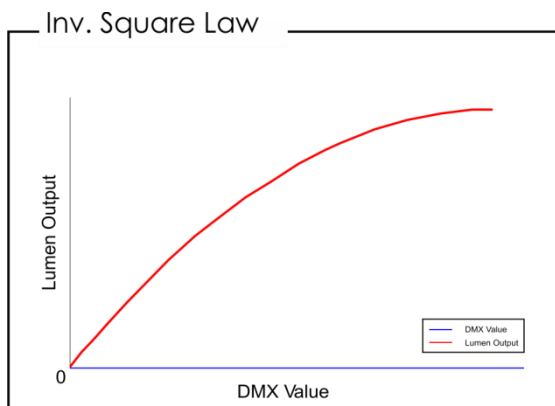
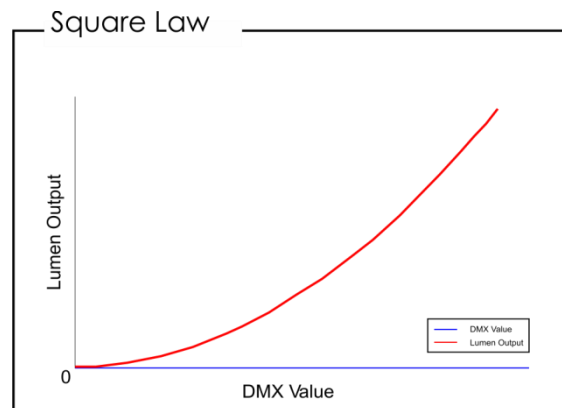
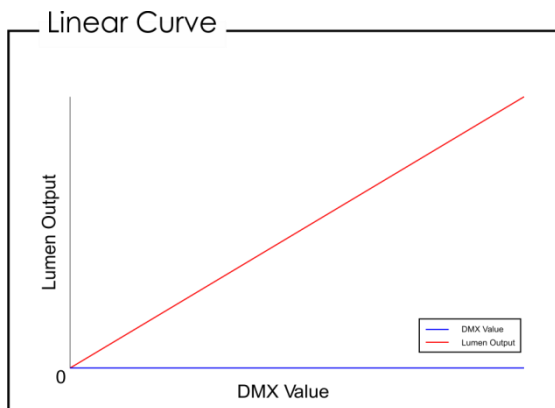

- 04) Press the **SET** button to confirm your choice.

6.2. Pixel Invert

In this menu you can adjust the Pixel direction of the device.

- 01) Press the **UP/DOWN** buttons until the display shows **Pixel Invert**.
- 02) Press the **SET** button to open the menu, the display will show:



- 03) Press the **UP/DOWN** buttons to select **Yes** or **No**.
- 04) If you choose **Yes** and confirm it with the **SET** button, the output of the device will be in the opposite pixel direction.
- 05) If you choose **No**, the output of the device will be in the default pixel direction.

6.3. PWM Frequency

In this menu you can choose several PWM frequencies.

- 01) Press the **UP/DOWN** buttons until the display shows **PWM Frequency**.
- 02) Press the **SET** button to open the menu, the display will show:

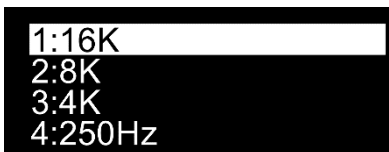

- 03) Press the **UP/DOWN** buttons to select one of the 4 options.
- 04) Press the **SET** button to confirm your choice.

6.4. DMX Fail

In this menu you can adjust the behaviour of the device in case of a DMX signal error.

- 01) Press the **UP/DOWN** buttons until the display shows **Dmx Fail**.
- 02) Press the **SET** button to open the menu, the display will show:

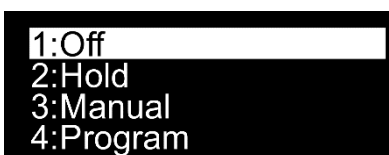

- 03) Press the **UP/DOWN** buttons to choose one of the 4 options.
- 04) If you choose **Off**, the output will blackout when a DMX signal error occurs.
- 05) If you choose **Hold**, the device will fall back on the last properly working DMX signal from before the DMX signal error, which ensures uninterrupted performance.
- 06) If you choose **Manual**, the device will fall back on the last setting in the Manual mode before the DMX signal error.
- 07) If you choose **Program**, the device will fall back on the last setting in the Program mode before the DMX signal error.
- 08) Press the **SET** button to confirm your choice.

6.5. DMX Sync

In this menu you can set the DMX synchronisation of the device.

- 01) Press the **UP/DOWN** buttons until the display shows **Dmx Sync**.
- 02) Press the **SET** button to open the menu, the display will show:

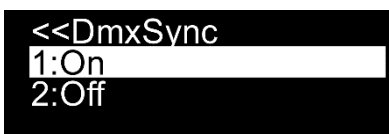

- 03) Press the **UP/DOWN** buttons to select **On** or **Off**.
- 04) The Sync option is a tool which helps to keep multiple fixtures synchronized, when using them in master slave mode.
- 05) If you choose **On**, the synchronization function is activated, this is recommended.
- 06) If you choose **Off**, the synchronization function is not activated.
- 07) Press the **SET** button to confirm your choice.

6.6. Lock

In this menu you can select whether the safety lock is active or not.

- 01) Press the **UP/DOWN** buttons until the display shows **Lock**.
- 02) Press the **SET** button to open the menu, the display will show:



- 03) Press the **UP/DOWN** buttons to select **On** or **Off**.
- 04) If you choose **On** and confirm it with the **SET** button, the device will be in Lock mode. You will need to insert the password in order to access the main menu. Simultaneously press the **MODE** and **SET** button for 3 seconds and you will be able to access the main menu.
- 05) If you choose **Off**, the main menu will remain unlocked.
- 06) Press the **SET** button to confirm your choice.

6.7. Key Backlight

In this menu you can select whether the menu buttons light up or not.

- 01) Press the **UP/DOWN** buttons until the display shows **Key Backlight**.
- 02) Press the **SET** button to open the menu, the display will show:



- 03) Press the **UP/DOWN** buttons to select **On** or **Off**.
- 04) If you choose **On**, the menu buttons will light up.
- 05) If you choose **Off**, the menu buttons will not light up.
- 06) Press the **SET** button to confirm your choice.

6.8. Factory

In this menu you can reset to the default settings.

- 01) Press the **UP/DOWN** buttons until the display shows **Factory**.
- 02) Press the **SET** button to open the menu, the display will show:



- 03) Press the **UP/DOWN** buttons to select **Yes** or **No**.
- 04) If you choose **Yes** and confirm it with the **SET** button, the device will reset to its factory default settings.
- 05) If you choose **No**, the device will keep current settings.

7. Information

With this menu you can view the currently installed software version and temperature

- 01) In main menu, press the **UP/DOWN** buttons until the display shows **Information**.
- 02) Press the **SET** button to open the menu, the display will show:

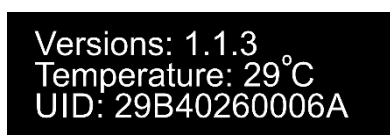

- 03) You can view the currently installed software version, the actual temperature and the UID number.
- 04) UID: the display shows the unique identification number of the device.
- 05) The model ID for the Candela Pix 50 is 29B40260.

DMX Channels**4 Channels****Channel 1 – Red Dimmer intensity**

0-255 Gradual adjustment Red from 0-100%

Channel 2 – Green Dimmer intensity

0-255 Gradual adjustment Green from 0-100%

Channel 3 – Blue Dimmer intensity

0-255 Gradual adjustment Blue from 0-100%

Channel 4 – White Dimmer intensity

0-255 Gradual adjustment White from 0-100%

6 Channels**Channel 1 – Master Dimmer intensity**

0-255 Gradual adjustment, from dark to brightest 0-100%

Channel 2 – Red Dimmer intensity (CH1 must be set between 1-255 )

0-255 Gradual adjustment Red from 0-100%

Channel 3 – Green Dimmer intensity (CH1 must be set between 1-255 )

0-255 Gradual adjustment Green from 0-100%

Channel 4 – Blue Dimmer intensity (CH1 must be set between 1-255 )

0-255 Gradual adjustment Blue from 0-100%

Channel 5 – White Dimmer intensity (CH1 must be set between 1-255 )

0-255 Gradual adjustment White from 0-100%

Channel 6 – Strobe (CH1 and CH2, CH3, CH4 or CH5 must be set between 1-255 )

0-10 Closed

11-255 Strobe flash frequency, from low to high frequency (0-20 Hz)

9 DMX Channels**Channel 1 – Master Dimmer intensity**

0-255 Gradual adjustment, from dark to brightest 0-100%

Channel 2 – Red Dimmer intensity (CH1 must be set between 1-255 )

0-255 Gradual adjustment Red from 0-100%

Channel 3 – Green Dimmer intensity (CH1 must be set between 1-255 )

0-255 Gradual adjustment Green from 0-100%

Channel 4 – Blue Dimmer intensity (CH1 must be set between 1-255 )

0-255 Gradual adjustment Blue from 0-100%

Channel 5 – White Dimmer intensity (CH1 must be set between 1-255 )

0-255 Gradual adjustment White from 0-100%

Channel 6 – Built-in programs (CH1 must be set between 1-255 )

0-5	No function
6-23	Program 1 (All colours full, cycle)
24-41	Program 2 (All colours full, fade)
42-59	Program 3 (All colours throb)
60-77	Program 4 (1-cell chase)
78-95	Program 5 (2-cell chase)
96-113	Program 6 (Bounce 2 cells)
114-131	Program 7 (Chase bounce build)
132-149	Program 8 (2-cell bounce in-out build)
150-167	Program 9 (2-cell bounce build)
168-185	Program 10 (Rainbow sweep in-out)
186-203	Program 11 (2 halves flash)
204-221	Program 12 (Rainbow sweep)
222-239	Program 13 (2 cells random flash)
240-255	Program 14 (Full mixed effect)

Channel 7 – Speed Built-in programs (CH6 must be set between 6-255 )

0-255 Speed adjustment, from slow to fast

Channel 8 – Color presets (CH1 must be set between 1-255 )

0-10	No function
11-16	Color 1 (R255, G000, B000, W000)
17-22	Color 2 (R255, G080, B000, W000)
23-28	Color 3 (R255, G108, B000, W000)
29-34	Color 4 (R255, G152, B000, W000)
35-40	Color 5 (R255, G163, B000, W000)
41-46	Color 6 (R247, G214, B000, W000)
47-52	Color 7 (R023, G215, B000, W000)
53-58	Color 8 (R225, G232, B000, W000)
59-64	Color 9 (R210, G255, B000, W000)
65-70	Color 10 (R145, G194, B000, W000)
71-76	Color 11 (R108, G226, B000, W000)
77-82	Color 12 (R080, G232, B000, W000)
83-88	Color 13 (R075, G255, B000, W000)
89-94	Color 14 (R032, G223, B000, W000)
95-100	Color 15 (R029, G255, B000, W000)
101-106	Color 16 (R000, G255, B000, W000)
107-112	Color 17 (R000, G255, B094, W000)
113-118	Color 18 (R000, G255, B143, W100)
119-124	Color 19 (R115, G255, B165, W000)
125-130	Color 20 (R205, G255, B199, W000)
131-136	Color 21 (R219, G232, B175, W000)
137-142	Color 22 (R213, G220, B222, W000)
143-148	Color 23 (R137, G255, B227, W000)
149-154	Color 24 (R149, G246, B255, W000)
155-160	Color 25 (R000, G255, B234, W000)
161-166	Color 26 (R000, G199, B255, W000)
167-172	Color 27 (R000, G078, B255, W000)
173-178	Color 28 (R000, G000, B255, W000)
179-184	Color 29 (R040, G001, B255, W000)
185-190	Color 30 (R226, G175, B226, W000)
191-196	Color 31 (R255, G138, B219, W000)
197-202	Color 32 (R255, G059, B113, W000)
203-208	Color 33 (R255, G000, B044, W000)
209-214	Color 34 (R214, G134, B048, W000)
215-220	Color 35 (R255, G235, B052, W000)
221-226	Color 36 (R255, G200, B040, W090)
227-232	Color 37 (R000, G000, B000, W255)
233-255	Color 38 (R255, G255, B255, W255)

Channel 9 – Strobe (CH1 and CH2, CH3, CH4, CH5, CH6 or CH8 must be set between 1-255 )

0-10	Closed
11-255	Strobe flash frequency, from low to high frequency (0-20 Hz)

28 DMX Channels**Channel 1 – Red Pixel LED 1**

0-255 Gradual adjustment Red from 0 – 100%

Channel 2 – Green Pixel LED 1

0-255 Gradual adjustment Green from 0 – 100%

Channel 3 – Blue Pixel LED 1

0-255 Gradual adjustment Blue from 0 – 100%

Channel 4 – White Pixel LED 1

0-255 Gradual adjustment White from 0 – 100%

Channel 5 – Red Pixel LED 2

0-255 Gradual adjustment Redr from 0 – 100%

Channel 6 – Green Pixel LED 2

0-255 Gradual adjustment Green from 0 – 100%

Channel 7 – Blue Pixel LED 2

0-255 Gradual adjustment Blue from 0 – 100%

Channel 8 – White Pixel LED 2

0-255 Gradual adjustment White from 0 – 100%

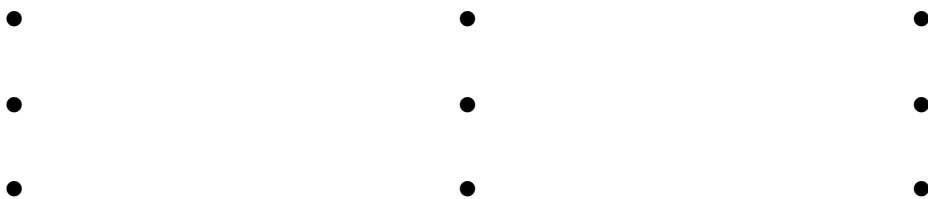
**Channel 21– Red Pixel LED 6**

0-255 Gradual adjustment Red from 0 – 100%

Channel 22 – Green Pixel LED 6

0-255 Gradual adjustment Green from 0 – 100%

Channel 23 – Blue Pixel LED 6

0-255 Gradual adjustment Blue from 0 – 100%

Channel 24 – White Pixel LED 6

0-255 Gradual adjustment White from 0 – 100%

Channel 25 – Red Pixel LED 7

0-255 Gradual adjustment Red from 0 – 100%

Channel 26 – Green Pixel LED 7

0-255 Gradual adjustment Green from 0 – 100%

Channel 27 – Blue Pixel LED 7

0-255 Gradual adjustment Blue from 0 – 100%

Channel 28 – White Pixel LED 7

0-255 Gradual adjustment White from 0 – 100%

Maintenance

The operator has to make sure that safety-relating and machine-technical installations are to be inspected by an expert after every year in the course of an acceptance test.

The operator has to make sure that safety-relating and machine-technical installations are to be inspected by a skilled person once a year.

The following points have to be considered during the inspection:

- 01) All screws used for installing the device or parts of the device have to be tightly connected and must not be corroded.
- 02) There may not be any deformations on housings, fixations and installation spots.
- 03) Mechanically moving parts like axles, eyes and others may not show any traces of wearing.
- 04) The electric power supply cables must not show any damages or material fatigue.

The Candela Pix 50 requires almost no maintenance. However, you should keep the unit clean.

Otherwise, the fixture's light-output will be significantly reduced. Disconnect the mains power supply and then wipe the cover with a damp cloth. Wipe the front glass panel clean with glass cleaner and a soft cloth. Do not use alcohol or solvents.

The front glass panel will require weekly cleaning, as smoke-fluid tends to build up residues, reducing the light-output very quickly.

Keep connections clean. Disconnect electric power, and then wipe the DMX and audio connections with a damp cloth. Make sure connections are thoroughly dry before linking equipment or supplying electric power.

Troubleshooting

No Light

This troubleshooting guide is meant to help solve simple problems.

If a problem occurs, follow the steps below in sequence until a solution is found. Once the unit operates properly, do not carry out the following steps.

If the light effect does not operate properly, refer servicing to a technician.

Suspect three potential problem areas as the power supply, the LEDs, the internal fuse.

- 01) Power supply. Check that the unit is plugged into an appropriate power supply.
- 02) The LEDs. Return the Candela Pix to your Showtec dealer.
- 03) The fuse. Return the Candela Pix to your Showtec dealer.
- 04) If all of the above appears to be in order, switch the unit on again.
- 05) If you are unable to determine the cause of the problem, do not open the Candela Pix, as this may damage the unit and the warranty will become void.
- 06) Return the device to your Showtec dealer.

No Response to DMX

Response: Suspect the DMX cable or connectors, a controller malfunction, a light effect DMX card malfunction.

- 01) Check the DMX setting. Make sure that DMX addresses are correct.
- 02) Check the DMX cable: Unplug the unit; change the DMX cable; then reconnect to electrical power. Try your DMX control again.
- 03) Determine whether the controller or light effect is to blame. Does the controller operate properly with other DMX products? If not, take the controller in for repair. If it does, take the DMX cable and the light effect to a qualified technician.

Problem	Probable cause(s)	Solution
One or more fixtures do not function at all	No power to the fixture	<ul style="list-style-type: none"> • Check if power is switched on and cables are plugged in
	Internal fuse blown	<ul style="list-style-type: none"> • Return the device to your local Showtec dealer
Fixtures reset correctly, but all respond erratically or not at all to the controller	The controller is not connected	<ul style="list-style-type: none"> • Connect controller
	3-pin XLR Out of the controller does not match XLR Out of the first fixture on the link (i.e. signal is reversed)	<ul style="list-style-type: none"> • Install a phase reversing cable between the controller and the first fixture on the link
Fixtures reset correctly, but some respond erratically or not at all to the controller	Poor data quality	<ul style="list-style-type: none"> • Check data quality. If much lower than 100 percent, the problem may be a bad data link connection, poor quality or broken cables, missing termination plug, or a defective fixture disturbing the link
	Bad data link connection	<ul style="list-style-type: none"> • Inspect connections and cables. Correct poor connections. Repair or replace damaged cables
	Data link not terminated with 120 Ohm termination plug	<ul style="list-style-type: none"> • Insert termination plug in output jack of the last fixture on the link
	Incorrect addressing of the fixtures	<ul style="list-style-type: none"> • Check address setting
	One of the fixtures is defective and disturbs data transmission on the link	<ul style="list-style-type: none"> • Bypass one fixture at a time until normal operation is restored: unplug both connectors and connect them directly together • Have the defective fixture serviced by a qualified technician
	3-pin XLR Out on the fixtures does not match (pins 2 and 3 reversed)	<ul style="list-style-type: none"> • Install a phase-reversing cable between the fixtures or swap pin 2 and 3 in the fixture that behaves erratically
No light or LEDs cuts out intermittently	Fixture is too hot	<ul style="list-style-type: none"> • Allow the fixture to cool down • Clean the fan • Turn up the air conditioning
	LEDs damaged	<ul style="list-style-type: none"> • Disconnect the fixture and return it to your dealer
	The power supply settings do not match local AC voltage and frequency	<ul style="list-style-type: none"> • Disconnect fixture. Check settings and correct if necessary

Product Specifications

Model:	Showtec Candela Pix 50
Input Voltage:	100-240V AC, 50/60Hz
Consumption Power	118W@FO
Drive current:	1000mA
DMX linking:	30pcs
Dimensions:	510 x 150 x 230 mm (LxWxH) (incl. brackets)
Weight:	6,5 kg
Operating and Programming:	
Signal pin OUT:	Pin 1 (earth), pin 2 (-), pin 3 (+)
DMX Mode:	4, 6, 9 and 28 DMX channel operation
Signal input:	3-pin XLR male
Signal output:	3-pin XLR female
Electro-mechanical effects:	
Light source:	7 x 15W 4-in-1 RGBW LEDs
Lux @2m:	Red: 1733
	Green: 4680
	Blue: 810
	White: 5758
	Full Output: 9450
Beam Angle:	8°
Sections selectable:	7
Dimmer:	0-100%
Strobe:	0-20Hz
Color Range:	RGBW
Cooling:	Aluminum housing
Display:	OLED display
Housing:	Black aluminum
Lens Plate:	Tempered Glass
IP rating:	IP-65
DMX-control:	DMX512 via standard DMX-controller
Control:	Auto Program, Built-in programs, Manual, Master/Slave, DMX
Connections:	Dedicated PowerCON True 1 IP65 (IN/OUT), Dedicated 3 pin XLR IP65 (IN/OUT)
Built-in microphone	
Max. ambient temperature t_a :	40°C
Max. housing temperature t_B :	80°C
Minimum distance:	
Minimum distance from flammable surfaces:	0,5 m
Minimum distance to lighted object:	1 m

Design and product specifications are subject to change without prior notice



Website: www.Showtec.info

Email: service@highlite.com

Dimensions

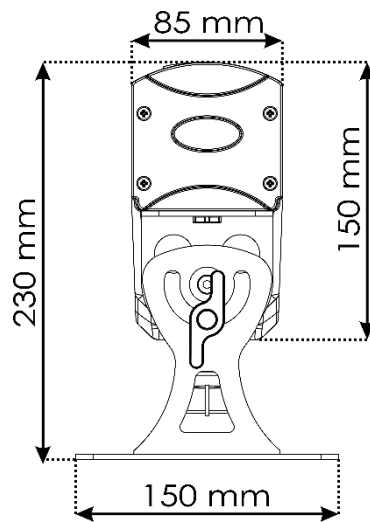
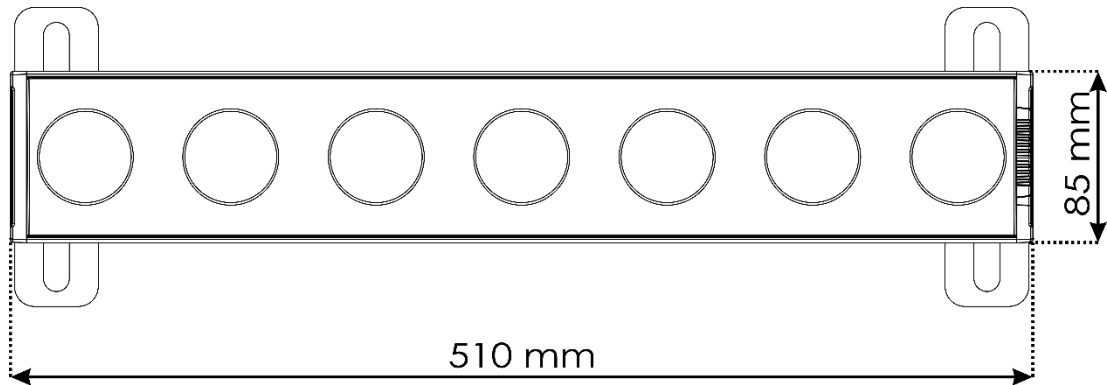



©2021 Showtec