

Lupo
Made in Italy

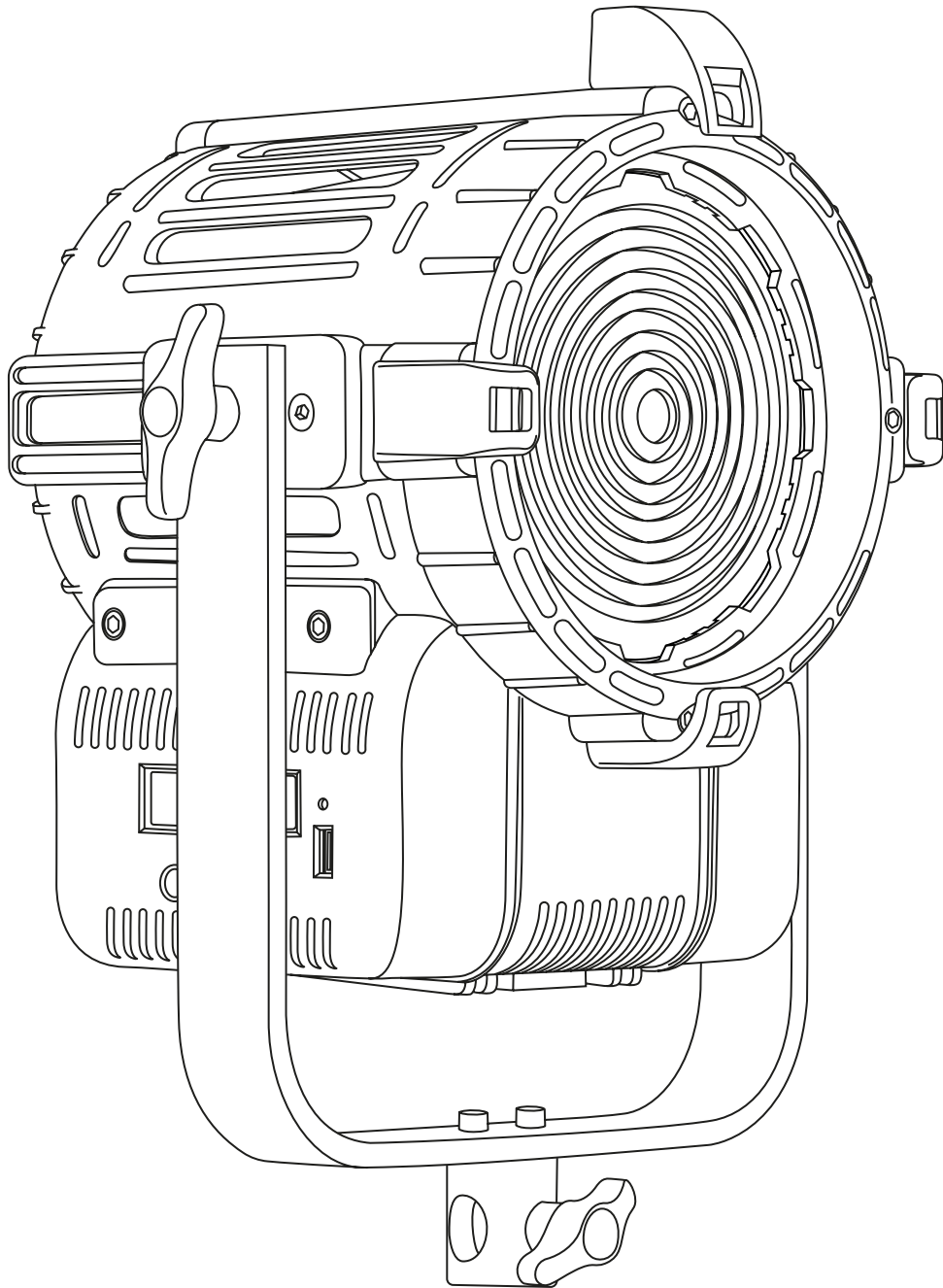

Cod 301 T PRO

Dayled 1000 PRO
3200 K

Technical Data

Technical Features

Dimensions (cm)	212 x 299 x 254 mm
Dimensions (in)	8.3 x 11.7 x 10 in
Weight (kg)	5 kg
Weight (lb)	11 lb
CRI (Colour Rendering Index)	> 97
TLCI (Television Lighting Consistency Index)	98
LED COB	110 W
Dimmer 0 - 100	included
Dimming curves mode	Linear, Exponential, Logarithmic
Connection for 14.8 V battery with standard XLR 4 pin connector (pin 1: negative / pin 4: positive)	included
Standard XLR 5 pin connectors to DMX console	included
Watt consumption	110 W
Watt output (equivalent to tungsten)	1000 W
Fresnel lens	150 mm
Firmware upgrades	through USB port
Colour temperature	3200 K - tungsten balanced
Voltage AC	90 V - 240 V
Light beam	10° - 60°
Frequency (input)	50 / 60 Hz
Compliance	CE

Photometric data

Distance	3200 K	
	spot	flood
Lux at 1 m - 3.2 ft	32000	7900
Lux at 2 m - 6.5 ft	8100	1800
Lux at 3 m - 9.8 ft	3500	860
Lux at 4 m - 13.1 ft	2000	500
Lux at 5 m - 16.4 ft	1250	340

Technical Drawing

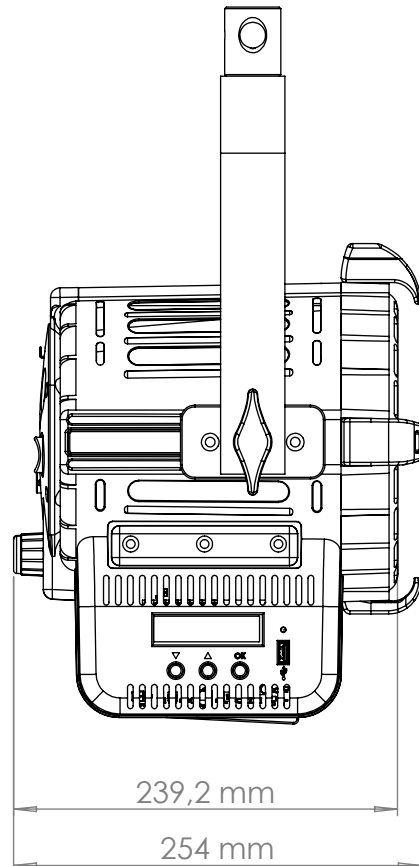
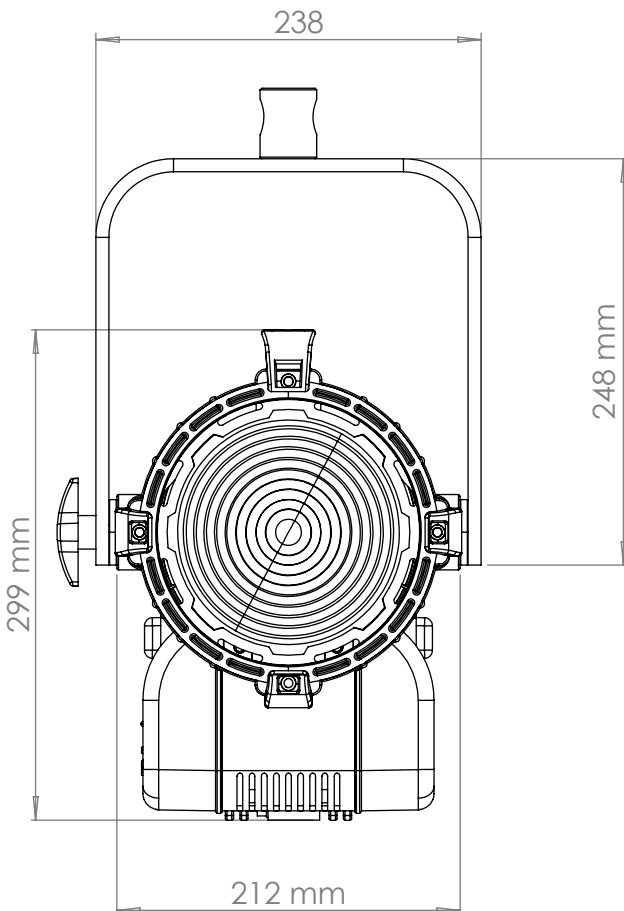
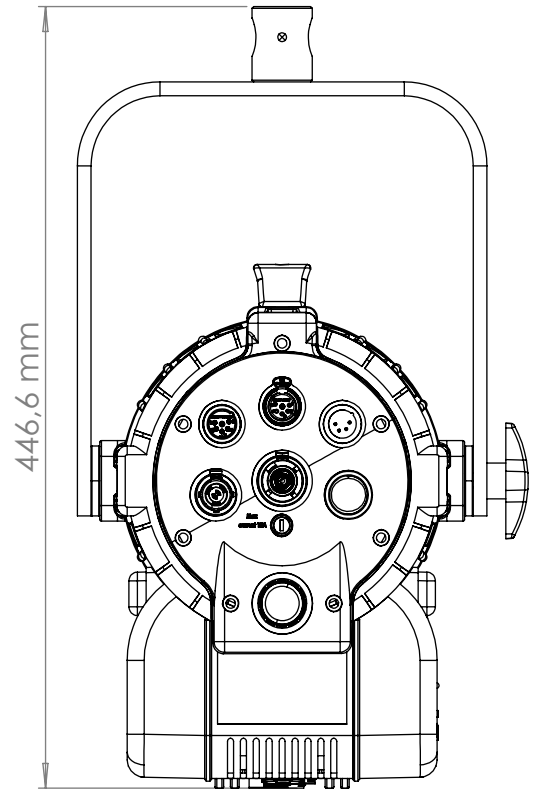
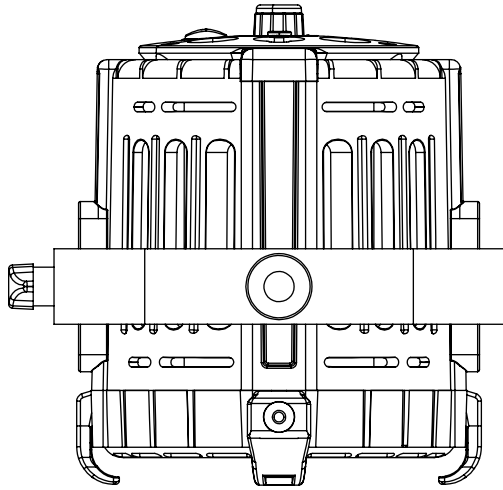

Lupo
Made in Italy

eqc
extreme quality control

Lupo srl - Via V. Sassi 28/30 Collegno (TO) - 10093 - Italy

Phone: +39 011 411 9919 / e-mail: contact@lupo.it / website: www.lupo.it

Extreme Quality Control S.L. - Calibre 55 - Collado Villalba - 28400 - Madrid, Spain

Phone: +34 918 505 087 / e-mail: info@eqcgrupo.com / website: www.eqcgrupo.com